



ZG3 series integrated PLC&HMI

User manual

WUXI XINJE ELECTRIC Co. Ltd.

No. PH C 09 201400902 3.3

This manual includes some basic precautions which you should follow to keep you safe and protect the products. These precautions are underlined with warning triangles in the manual. About other manuals that we do not mention please follow basic electric operating rules.

Precautions



Please follow the precautions. If not, it may lead the control system incorrect or abnormal, even cause fortune lose.

**Correct
Application**



The models could only be used according to the manual, and an only be used along with the peripheral equipments recognized or recommended by XINJE Electronic. They could only work normally in the condition of be transported, kept and installed correctly, also please operate and maintain them according to the recommendation.

WUXI XINJE ELECTRIC CO., LTD. Copyright reserved

Without exact paper file allowance, copy, translate or using the manual is not allowed. Disobey this, people should take the responsibility of loss. We reserve all the right of expansions and their design patent.

Duty Declare

We have checked the manual, its content fits the hardware and software of the products. As mistakes are unavoidable, we couldn't promise all correct. However, we would check the data in the manual frequently, and in the next edition, we will correct the necessary information. Your recommendation would be highly appreciated.

Catalog

SAFETY NOTES	5
1 ZG3 SERIES INTRODUCTION	1
1-1. INTRODUCTION	1
1-1-1. Characteristics	1
1-1-2. Name rule	1
1-2. GENERAL SPECIFICATION	2
1-2-1. Product specification	2
1-2-2. Special function	4
1-3. PART INTRODUCTION	5
1-3-2. Button function	6
1-3-3. Download port (COM0)	7
1-3-4. Communication port AB	7
1-3-5. USB download port	8
1-4. DIMENSION	9
2 I/O AND WIRING	10
2-1. INPUT SPEC	10
2-2. RELAY OUTPUT	12
2-3. TRANSISTOR OUTPUT	14
3 PLC AND HMI PROGRAMMING	16
3-1. PLC PROGRAMMING	16
3-2. INSTRUCTION LIST	16
3-2-1. Basic instructions	16
3-2-2. Application instructions	18
3-2-3. Special instructions	22
3-2-4. Soft component	23
3-3. HMI PROGRAMMING	24
APPENDIX 1 SPECIAL AUXILIARY REGISTER	27
APPENDIX 2 SPECIAL DATA REGISTERS	34
APPENDIX 3 SPECIAL FLASH REGISTER	49

Preface

Thank you for purchasing XINJE ZG3 series integral industrial controller, please read the manual before operating.

Manual purpose

- This manual provides user with the guide of using and operating our product, it includes the product characteristics, spec explanation, using method, etc.
- This manual contains product summarization, exterior layout, PLC program, and HMI editing. The details please refer to XD series PLC manual and TG series HMI manual.
- Summarization: introduce the product characteristics, specs, dimension, installation.
- Exterior layout: introduce the product power spec, in-out layout.
- PLC program: introduce how to program in PLC.
- HMI picture: introduce how to edit picture in TG.
- Exterior extension: introduce extension ability of the product.

Suitable people

This manual aims to below users:

- Terminal user
- Debugging person
- Technology support person

Make sure you have read the safety notice before operating.

Scope

This manual applies to the ZG3 series integral industrial controller.

Tele-document

XINJE provides user with press document and tele-document:

- User CD
Contained software, manual and application examples
- XINJE website
Welcome to www.XINJE.com to download center to find electronic document.

Contact us

If you have any questions, please contact us.

Tel: 86-0510-85134136

Fax: 86-0510-85111290

Address: 4th Floor, Building 7, Originality Industrial Park, Liyuan
Development Zone, Wuxi City, Jiangsu province, China

Safety notes

Read the manual carefully before operating. Be aware of the safety and correct operation. The content below is focus on ZG3 series products only.

Please safekeeping the manual, put in somewhere easy to get and read and give the manual to final user.

⦿ Notice items ⦿



ATTENTION

- Do not put the wire close to cable, keep 10cm distance at least.
- Do not change the inside module of product or it may cause fault, error action, loss, fire.
- When it smelly or noisy, cut the power immediately (short tweet after power on is normal).
- Do not press the screen with pen, screwdriver or other sharp tools, it may cause screen break or error.
- For installing the product, tighten the screws to avoid loose.
- Transport, install, store, assemble and maintain the product accurately to avoid breaking.



DANGEROUSNESS

- Confirm the power voltage and wire connection before turn on the power in order to avoid breaking
- Do not touch the connection point to avoid getting an electric shock
- Do not open the back cover board
- Cut all the power before installation and take-down to avoid error and fault
- Please use in the surrounding the manual stated to avoid accident
- Do not use the product under the condition of high frequency radiation, strong magnetic field to avoid interference

1 ZG3 series introduction

1-1. Introduction

1-1-1. Characteristics

- Integrated logical control, analog I/O, HMI in one unit
- Digital input: 16 points, optical isolation, high speed optical coupling please refer to 1-2-2.
 Digital output: 14 points, relay output/transistor output/relay & transistor output
 Analog extension: under development
- HMI screen is easy to edit, rich function, support touch screen
 - LCD: 800*480 pixels, 7 inches, 16000000 colors, use life up to 50000 hours
 - Support high speed count, high speed pulse, external interruption
 - Front panel waterproof level is IP65

1-1-2. Name rule

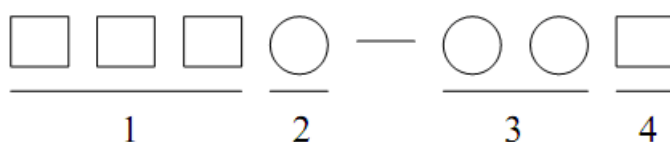

- 1: Series name ZG: 16 million colors touch screen
- 2: PLC type 3: XD3 series
- 3: I/O points 30: 16 input 14 output
- 4: Output type NPN type R: relay output
- T: transistor output
- PNP type PR: relay output
- PT: transistor output

model			Input point (DC24V)	Output point (R, T)
DC source				
	Relay output	Transistor output		
NPN	ZG3-30R	ZG3-30T	16 points	14 points
PNP	ZG3-30PR	ZG3-30PT	16 points	14 points

Extension BD board

The models include Z-3AD3PT-BD, Z-4AD2DA-A-BD. Please refer to Z series expansion BD manual.

1-2. General specification

1-2-1. Product specification

Electrical spec

	Item	Spec
Electrical	Input voltage	DC24V
	Rated frequency	~26.4V
	Allowable momentary power failure time	10ms DC24V
	Withstanding voltage	10A DC26.4V
	Insulation resistor	About 10M Ω , DC500V (signal and ground)
Environment	Operation temperature	0~50°C
	Storage temperature	-10~60°C
	Ambient humidity	20~85% (no condensation)
	Vibration resistance	10~25Hz (X, Y, Z each direction is 30 minutes 2G)
	Interference immunity	Voltage noise: 1000Vp-p
	Ambient air	No corrosive gas
	Protection	IP65 for the front cover
Structure	Cooling	Natural air cooling
	Dimension	200.4*146.9*49.0
	Installation dimension	192.0*138.5
Interface	Download port	RS-232/USB
	Communication port	RS-232/ RS-485

HMI spec

	Item	Spec
Screen	Type	16 million colors LCD
	LCD size	7 inches
	Use life	50000 hours, 24 hours run under the ambient temperature 25°C
	Display area	800*480
	Contrast	adjustable

	Language	Chinese, English, Spanish, Korean and so on
	Font	Any font and size
	Touch mode	4-wire resistance touch mode
Memory	Screen	128MB

PLC spec

Item		Spec	
Program execution mode		Cyclic scan	
Programming mode		Instruction, ladder chart, visual C	
Operation speed		0.05 μs	
Latched		Flash ROM and Li-battery	
User program capacity ^{※1}		128KB	
I/O points		Input 16 points; output 14 points	
Internal coil (X)		1048point: X0~X2027	
Internal coil (Y)		1048point: Y0~Y1037	
Internal coil (M、HM)		11008 point	M0~M7999 【HM0~HM959】 ^{※5} Special use ^{※6} SM0~SM2047
Flow (S)		1152 point	S0~S1023 【HS0~HS127】
Timer (T)	Points	704 points	T0~T575 【HT0~HT95】 Precise timer ET0~ET31
	Spec	100ms timer: 0.1~3276.7 s 10ms timer: 0.01~327.67 s 1ms timer: 0.001~32.767 s	
Counter (C)	Points	704 points	C0~C575 【HC0~HC95】 High speed counter HSC0~HSC31
	Spec	16-bit counter: 0~32767 32-bit counter: -2147483648~+2147483647	
Data register (D)		11548 words	D0~D7999 【HD0~HD999】 ^{※5} Special use ^{※6} SD0~SD2047 Special use ^{※6} HSD0~HSD499
FlashROM register (FD)		8144 words	FD0~FD6143 Special use ^{※6} SFD0~SFD1999
High speed functions		High speed count, pulse output, external interruption	
Scheduled scan time		0~99ms	
Password protection		6-bit ASCII	
Self diagnosis		Power-on self test, monitoring timer, grammar check	

※1: The max capacity in encrypting download mode

※2: I/O numbers means the input and output terminal numbers.

※3: X means input relay, the X points over input terminals can be mediate relay.

※4: Y means output relay, the Y points over output terminal can be mediate relay.

※5: **【】** means power failure area ,cannot change.

※6: Special register cannot use for other purposes .

※7: Input coil and output relay/transistor number is octal number system, other is decimal system.

※8: I/O which is not linked with outside facilities can be used for fast internal relay.

1-2-2. Special function

1. High speed count

ZG3-30T/R												
	Incremental mode							AB phase mode				
	HSC0	HSC2	HSC4	HSC6	HSC8	HSC10	HSC12	HSC0	HSC2	HSC4	HSC6	HSC8
Max frequency	80K	10K	10K					80K	10K	10K		
4-time frequency								2/4	2/4	2/4		
Count interruption	√	√	√					√	√	√		
X000	U							A				
X001								B				
X002								Z				
X003		U							A			
X004									B			
X005									Z			
X006			U							A		
X007										B		
X010										Z		
X011												

2.High speed pulse output

- ZG3-30T: Y0, Y1, max speed is 200kHz
- ZG3-30R: not support

3. External interruption

Input	pointer		Suppress interruption
	Rising interruption	Falling interruption	
X2	I0000	I0001	SM050
X3	I0100	I0101	SM051
X4	I0200	I0201	SM053
X5	I0300	I0301	SM054
X6	I0400	I0401	SM055
X7	I0500	I0501	SM056

X10	I0600	I0601	SM056
X11	I0700	I0701	SM057
X12	I0800	I0801	SM058
X13	I0900	I0901	SM059

Notes:

1. the details please refer to XD3 series PLC manual.
2. the external interruption will not execute after suppress interruption coil is ON.

4. Frequency measurement

Model		X ID	Max frequency
ZG3 series	30 points	X0	80KHz
		X3	10KHz
		X6	10KHz

1-3. Part introduction

1-3-1. Structure

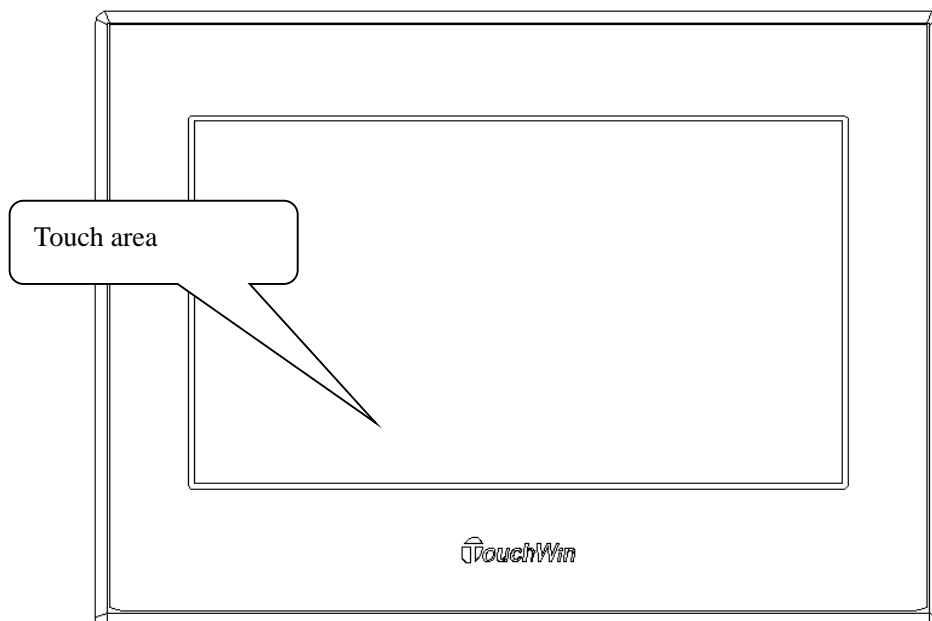

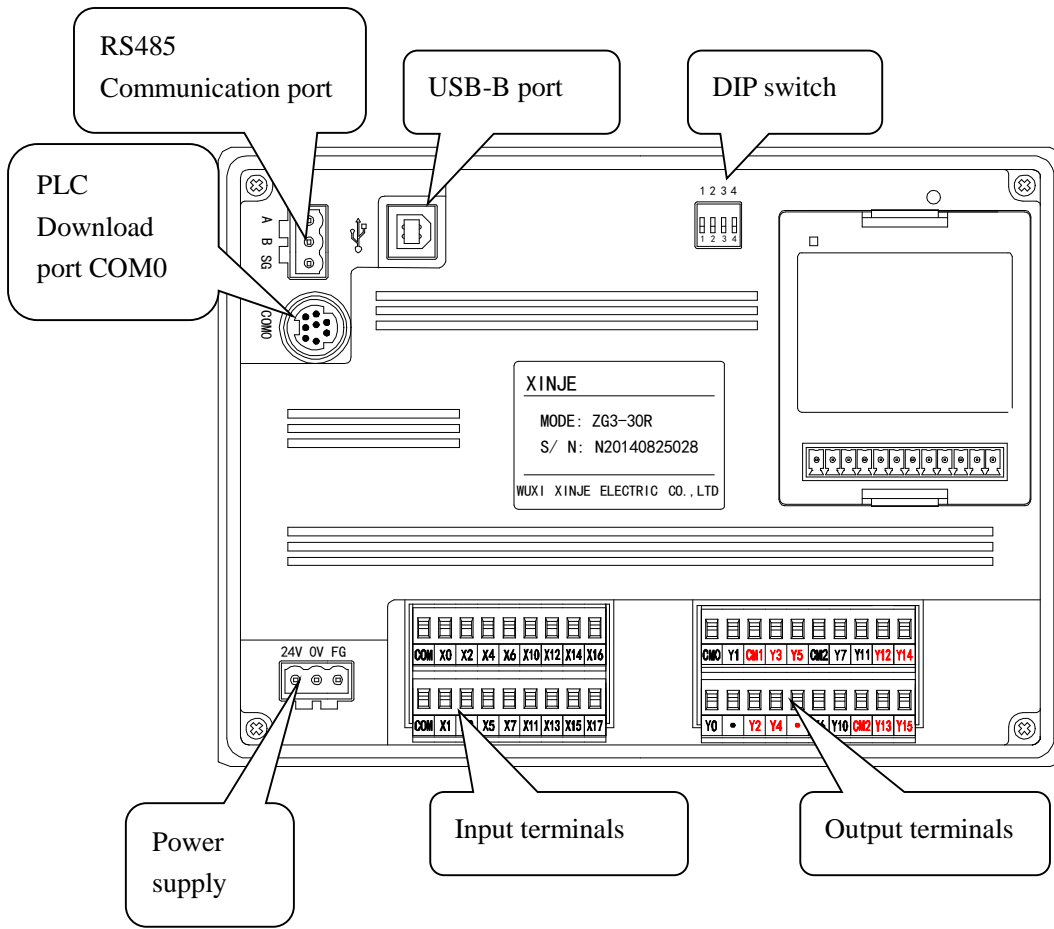

1-3-2. Button function

1. Power supply terminal

Power supply: DC24V

0V
24V
FG

2. I/O terminals

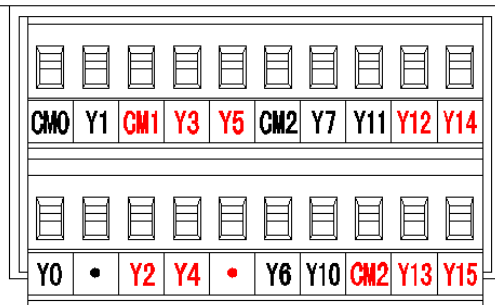
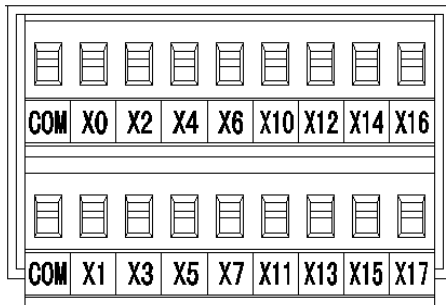

1-3-3. Download port (COM0)

The download port COM0 accords to RS232. It can download PLC program.

Pin	Function
Pin2	PRG
Pin4	RxD
Pin5	TxD
Pin6	VCC
Pin8	GND

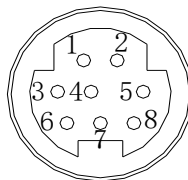

Please use XINJE company programming cable, if no cables, make it by yourself according to the below diagram:

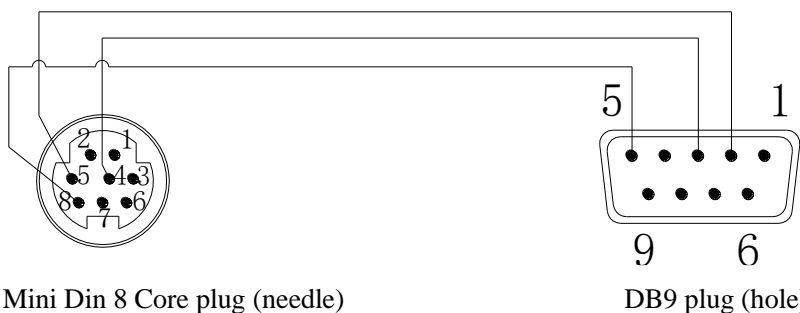

Mini Din 8 Core plug (needle)

DB9 plug (hole)

Notes: do not change the communication parameter of COM0 (PLC port1), otherwise PLC cannot connect to the PC.

1-3-4. Communication port AB

ZG3 integrated communication port is PLC communication port, RS485 (Serial port2).

Under factory setting, you can use this port to download and upload PLC program. It can also communicate with external sensors, instrumentation and other equipments.

Here are the port diagram:

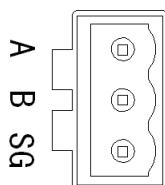

Communication parameters:

Station number	Modbus station 1~254, 255(FF) is free format
----------------	--

	communication
Baud rate	300bps~115.2Kbps
Data bit	8 data bits, 7data bits
Stop bit	2 stop bits, 1 stop bit
Checking	Even, odd, no parity

Note:

1. For ZG3 hardware version below v3.1.1, when using RS485 to communicate with other device, it cannot change the communication parameters, please only use the default parameters.
The default parameters: station no.1, baud rate 19200bps, 8 data bits, 1 stop bit, even parity.
2. For ZG3 hardware version up v3.1.1, the RS485 communication parameters can be changed.

1-3-5. USB download port

ZG3 integrated controller USB-B download port is only for HMI to download, it can be very fast, reaching 480Mbps.

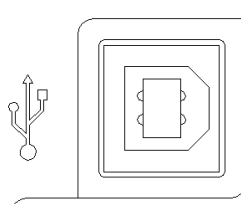

Under special environment, the HMI cannot download or it cannot reveal after download. Please force download.

Instructions :

- (1) Please make ZG3 power off, turn on switch 2.
- (2) Please make ZG3 power on, linking with USB to download the program.
- (3) when it finished, turn off switch 2, re-power on the ZG3.

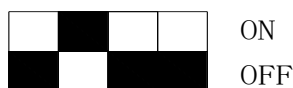
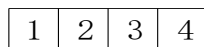

4-bits DIP switch is shown as below:

Switch	Switch1	Switch2	Switch3	Switch4	function
State	ON	OFF	OFF	OFF	Not defined
	OFF	ON	OFF	OFF	Force download
	OFF	OFF	ON	OFF	System menu: time calibration, touch calibration
	OFF	OFF	OFF	ON	Internal inspection mode (not recommended)

1-4. Dimension

- Product dimension (unit: mm)

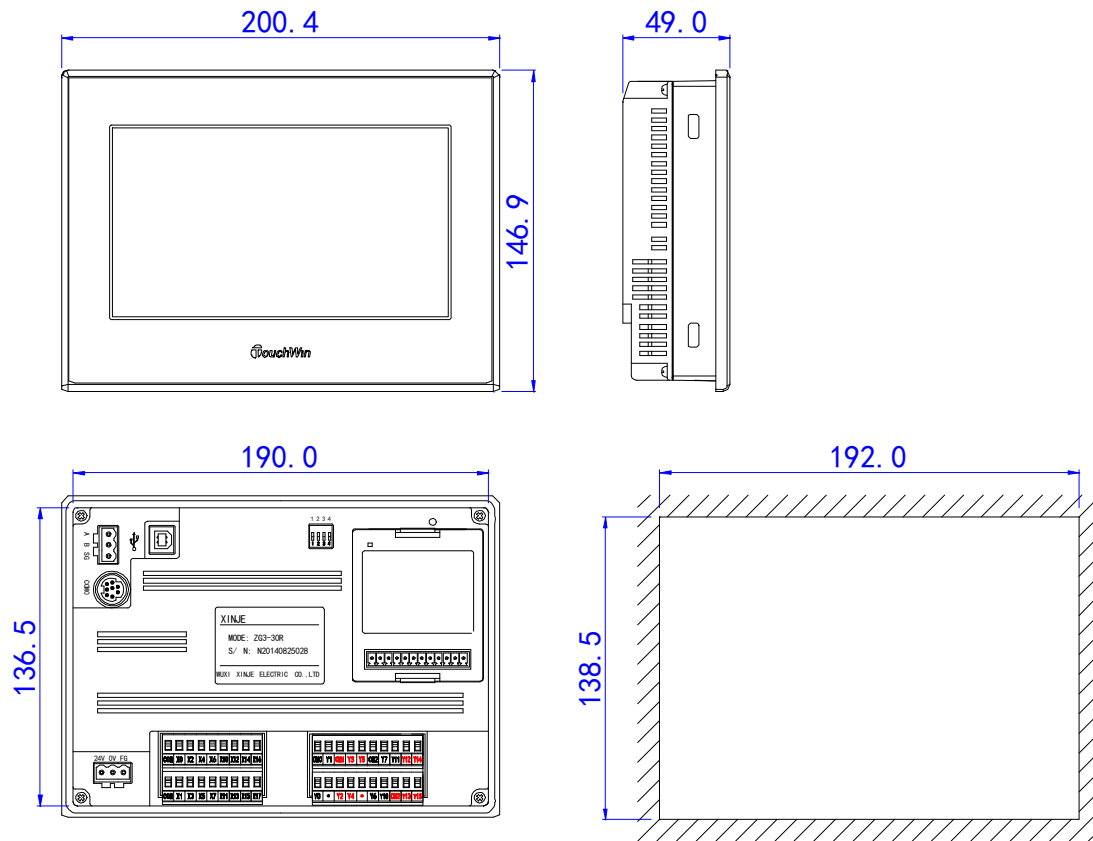

2 I/O and wiring

2-1. Input spec

Basic unit

Input signal voltage	DC24V \pm 10%
Input signal current	7mA/DC24V
Input ON current	Above 4.5mA
Input OFF current	Below 1.5mA
Input response time	About 10ms
Input signal format	Point input or NPN collector open transistor
Circuit insulation	Optical coupling insulation
Input action display	LED is ON when input ON

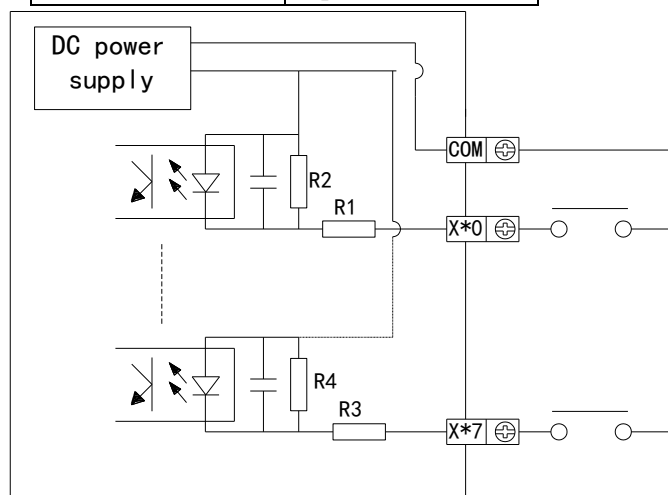

Input wiring

The input current of ZG3 series is supplied by internal 24V power supply. If using external power supply to drive the optical-electricity sensor, the supplier should be DC24V \pm 4V. The output transistor of sensor should be NPN open collector.

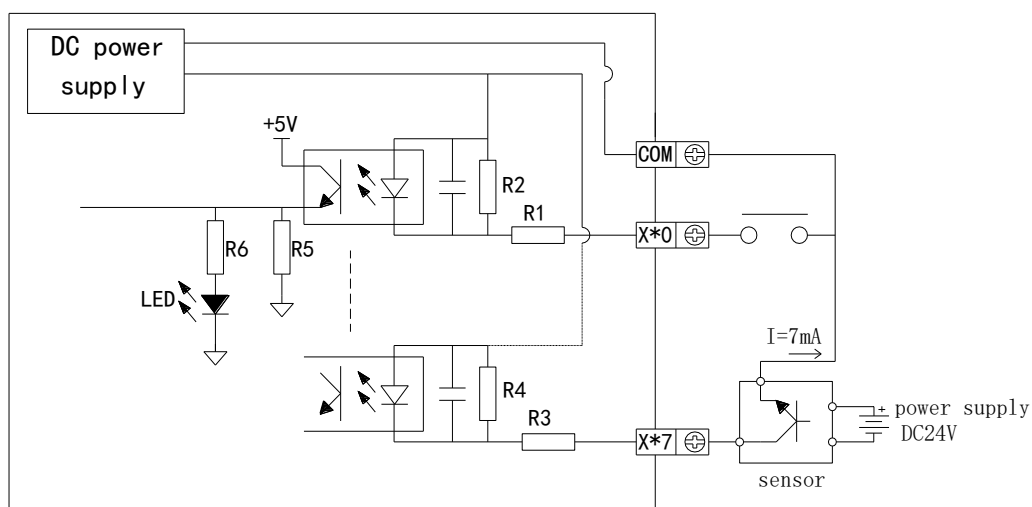

- **Input points**
Connect input point and com point with non-voltage point or NPN open collector transistor to turn on the input.
- **Input loop**
The first loop and the second loop are insulated by optical coupler, the second loop has C-R filter which can prevent wrong action caused by industry noise or input points oscillation. As the result, there will be a response delay for 10ms to the input points. There is digital filter in the input points.
- **Input sensitivity**
Input current is DC 24V 7mA. To make the input reliable, the ON current should be above 3.5mA, the OFF current should be below 1.5mA.

Typical wiring

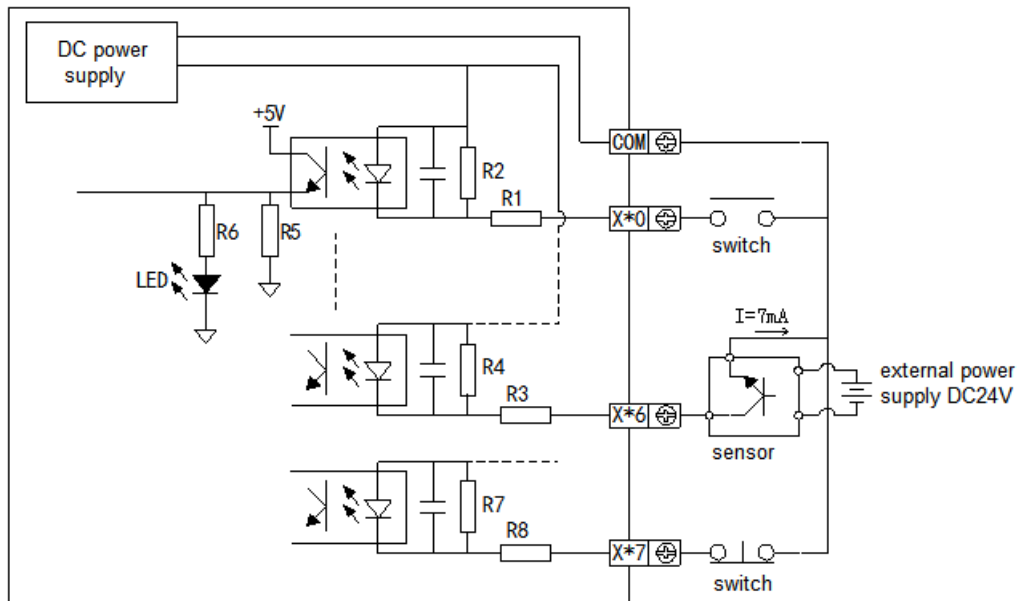

2-2. Relay output

Relay output spec

Power supply		Below AC250V, DC30V
Circuit insulation		Machinery insulation
Max loader	Resistance load	3A
	Inductance load	80VA
	Lamp load	100W
Min loader		DC5V 2mA
Response time	OFF→ON	10ms
	ON→OFF	10ms

Relay output circuit

- Output points
Relay output has 4 common points. Different units can drive the loader of different power-voltage systems.
- Loop insulation
It is electric insulated between relay output point and outside load circuit.
- Action indication
Relay output coil produces close sound when it is on.
- Response time
The response time is about 10ms transferring the ON or OFF signal from relay output coil to

the output connection.

➤ Output current

Output current is 3A per point to drive resistance load for voltage below AC250V.

Inductance load is below 80VA (AC100V or AC200V) and lamp load is below 100W (AC100V or AC200V).

➤ Open leakage current

There is no leakage current when output point is OFF, it can drive neon light.

➤ Use life of relay output point

The standard life of inductance load such as contactor, solenoid valve: according to our experiment results, 20VA load is about 3 million times, 35VA load is about 1 million times, 80VA load is about 0.2 million times. However, the life will extend if parallel connect surge absorber with the load.

Typical output wiring

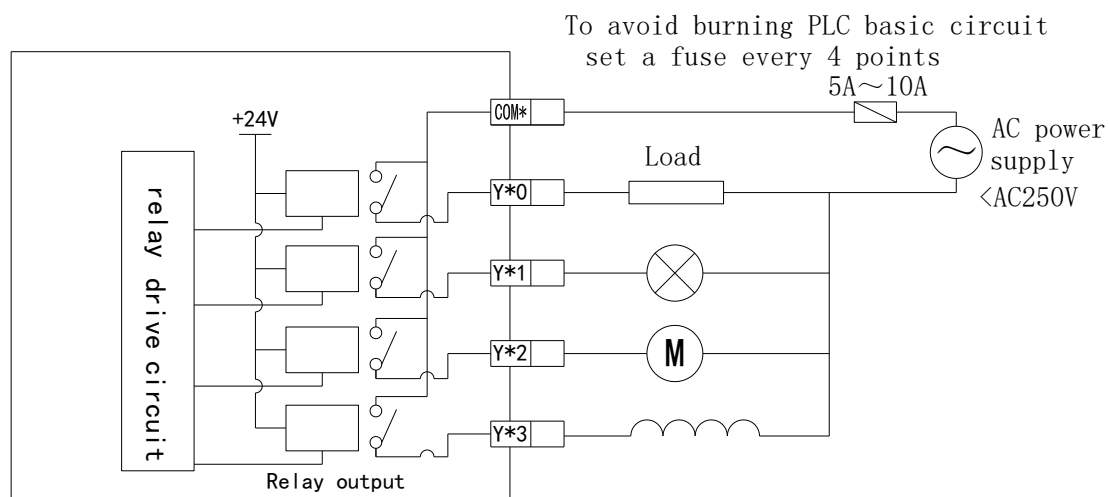

Note: T type (Y0, Y1) has no relay output, do not connect AC220V, or the product will be broken.

Output circuit construction

- ◆ For DC inductance load, please parallel connect with commutate diode. If not connect with the commutate diode, the point's life will be decreased greatly. Please choose the commutate diode which allow inverse voltage endurance up to 5~10 times of the load's voltage, ordinal current exceeds load current.
- ◆ Parallel connect AC inductance load with surge absorber can reduce noise and extend useful life of the points.

DC load

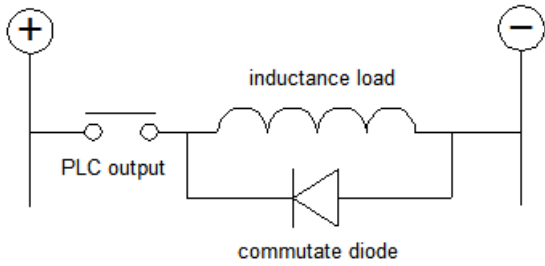

AC load

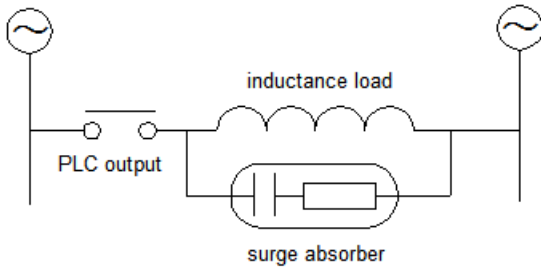

2-3. Transistor output

High speed pulse output

To avoid burning PLC basic circuit
use suitable fuse for the load

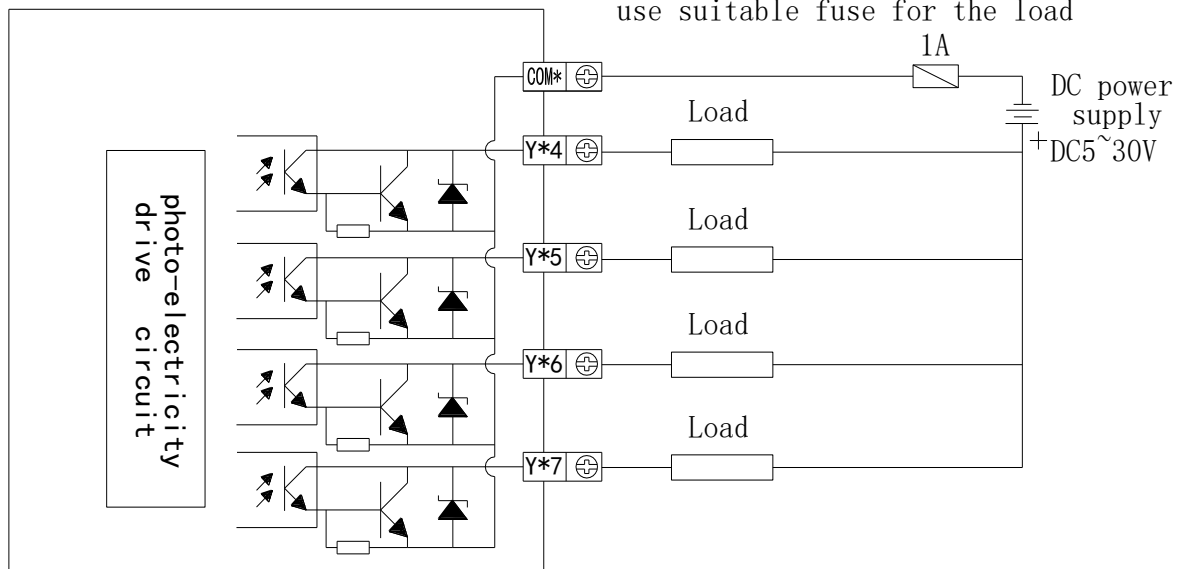

Wiring of pulse output and servo

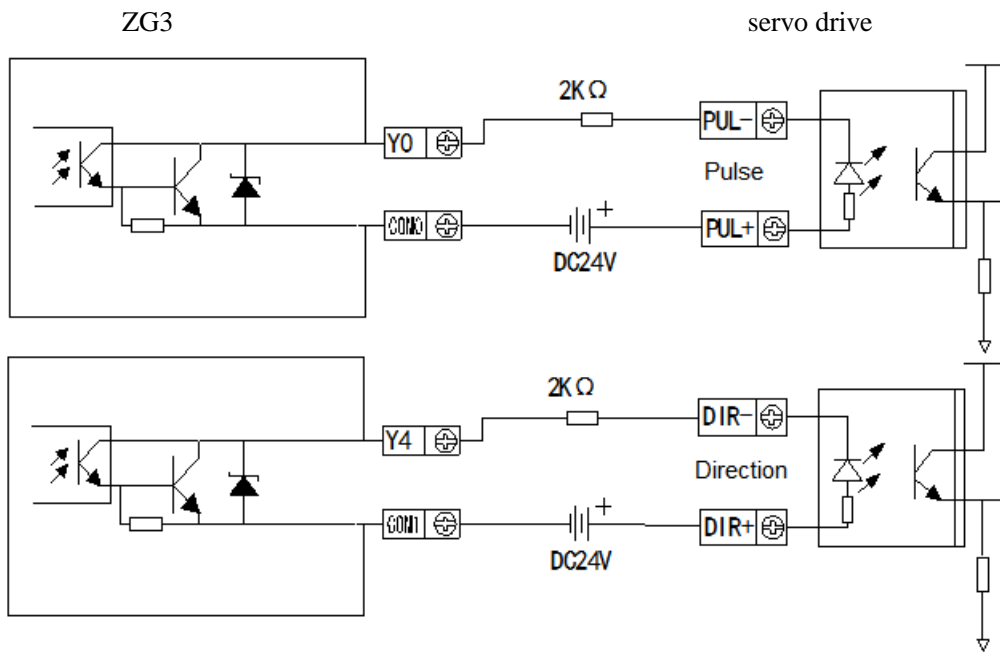

Make sure the current of servo drive optical coupling input is 8~15mA.

3 PLC and HMI programming

3-1. PLC programming

When programming, please use XDPro v3.2 and up, because it is new.

Note: The details please refer to XD3 instruction manual.

3-2. Instruction list

3-2-1. Basic instructions

Instruction	Function
LD	Initial logic normally open contactor
LDD	Directly from the contact read state
LDI	Initial logic normally close contactor
LDDI	Direct read normally closed contact
LDP	Rising edge detection algorithm
LDF	Falling edge detection operation began
AND	Serial connection normally open contactor
ANDD	Directly from the contact read state
ANI	Serial connection normally close contactor
ANDDI	Direct read normally closed contact
ANDP	Rising edge detection in series connection
ANDF	Falling edge detection in series connection

OR	Parallel connection normally open contactor
ORD	Directly from the contact read state
ORI	Parallel connection normally close contactor
ORDI	Direct read normally closed contact
ORP	Pulse rising edge detection parallel connection
ORF	Parallel connection of pulse falling edge detection
ANB	Series connection of parallel circuit block
ORB	Initial logic rising-edge of pulse
OUT	Coil drive
OUTD	Output to the contactor
SET	Keep the coil ON
RST	Clear the coil-ON state
PLS	Rising edge detection instruction
PLF	Falling edge detection instruction
MCS	Connecting coil instruction for common serial points
MCR	Read normally open contactor, serial connection
ALTI	Read normally close contactor, serial connection
RST	Read normally open contactor, parallel connection
PLS	ON for one scanning period at rising-edge of pulse
PLF	ON for one scanning period at falling-edge of pulse
MCS	Connecting coil instruction for common serial points
MCR	Removal of common serial points
ALT	Negate the coil
RST	Reset the contactor, clear the current value

TMR	Timer drive
END	Operate output/input and return to step 0
GROUP	Block folding start
GROUPE	Block folding end

3-2-2. Application instructions

Type	Instruction	Function
Process	CJ	Condition jump
	CALL	Call the subprogram
	SRET	Subprogram return
	STL	Process start
	STLE	Process end
	SET	Open assigned process, close current process
	ST	Open assigned process, not close current process
	FOR	Cycle start
	NEXT	Cycle end
	FEND	Main program end
Data comparison	LD=	Initial logic ON when (S1)=(S2)
	LD>	Initial logic ON when (S1)>(S2)
	LD<	Initial logic ON when (S1)<(S2)
	LD<>	Initial logic ON when (S1)≠(S2)
	LD>=	Initial logic ON when (S1)≥(S2)
	LD<=	Initial logic ON when (S1)≤(S2)
	AND=	Serial connection ON when (S1)=(S2)

	AND>	Serial connection ON when (S1)>(S2)
	AND<	Serial connection ON when (S1)<(S2)
	AND<>	Serial connection ON when (S1)≠(S2)
	AND>=	Serial connection ON when (S1)≥(S2)
	AND<=	Serial connection ON when (S1)≤(S2)
	OR=	Parallel connection ON when (S1)=(S2)
	OR>	Parallel connection ON when (S1)>(S2)
	OR<	Parallel connection ON when (S1)<(S2)
	OR<>	Parallel connection ON when (S1)≠(S2)
	OR>=	Parallel connection ON when (S1)≥(S2)
	OR<=	Parallel connection ON when (S1)≤(S2)
Data transmission	CMP	Data comparison
	ZCP	Data zone comparison
	MOV	Data transmission
	BMOV	Data block transmission
	FMOV	Multi-point repeat transmission
	EMOV	Float transmission
	FWRT	Write into FlashROM
	MSET	Multi-set on
	ZRST	Multi-reset
	SWAP	Exchange the high byte and low byte
	XCH	Exchange two values
Data calculation	ADD	Addition
	SUB	Subtraction

	MUL	Multiplication
	DIV	Division
	INC	Plus one
	DEC	Minus one

Type	Instruction	Function
Data calculation	MEAN	Get the mean value
	WAND	Logic and
	WOR	Logic or
	WXOR	Logic xor
	CML	Negate
	NEG	Negative
Data shift	SHL	Arithmetic shift left
	SHR	Arithmetic shift right
	LSL	Logic shift left
	LSR	Logic shift right
	ROL	Rotate left
	ROR	Rotate right
	SFTL	Bit shift left
	SFTR	Bit shift right
	WSFL	Word shift left
	WSFR	Word shift right
Data conversion	WTD	Word convert to double word
	FLT	16-bit integer convert to float

	FLTD	64-bit integer convert to float
	INT	Float convert to integer
	BIN	BCD convert to binary
	BCD	Binary convert to BCD
	ASCI	Hex convert to ASCII
	HEX	ASCII convert to hex
	DECO	Decoding
	ENCO	High-bit encoding
	ENCOL	Low-bit encoding
	GRY	Binary convert to gray code
	GBIN	Gray code convert to binary
Float calculation	ECMP	Float comparison
	EZCP	Float zone comparison
	EADD	Float addition
	ESUB	Float subtraction
	EMUL	Float multiplication
	EDIV	Float division
	ESQR	Float square
	SIN	Float sine
	COS	Float cosine
	TAN	Float tangent
	ASIN	Float arcsine
	ACOS	Float arccosine
	ATAN	Float arctangent

Clock	TRD	Read clock data
	TWR	Write clock data
	TCMP	Clock comparison

3-2-3. Special instructions

Type	Instruction	Function
High-speed count	PLSR	Multiple pulse output
	PLSF	Variable frequency pulse output
	STOP	Pulse stop
	ZRN	Mechanical origin regression
	DMOV	32 bit high-speed count read
	DMOV	32 bit high speed technology writing
	RST	High-speed count reset
MODBUS communication	COLR	MODBUS read coil
	INPR	MODBUS read input coil
	COLW	MODBUS write single coil
	MCLW	MODBUS write multi-coil
	REGR	MODBUS read register
	INRR	MODBUS read input register
	REGW	MODBUS write single register
	MRGW	MODBUS write multi-register
	BIT_READ	X-NET Read instruction
	BIT_WRITE	X-NET Write instruction
	REG_READ	X-NET Read register instruction
	REG_WRITE	X-NET Write register instruction

Type	Instruction	Function
Precise timing	STR	Precise timing
	STRR	Read precise timing register
	STRS	Stop precise timing
Interruption	EI	Enable the interruption
	DI	Disable the interruption
	IRET	Interruption return
Sequence block	SBLOCK	Block start
	SBGOON	Continue running the stop block
Read &write module	FROM	Read the module
	TO	Write the module
Others	FRQM	Frequency measurement
	PWM	Pulse width modulation
	PID	PID control
	NAME_C	C block

❖ The details please refer to XD series instruction manual.

3-2-4. Soft component

	Name	Range	points
X	Input	X0~X21	18
Y	Output	Y0~Y15	14
M	Internal relay	M0~M7999	8000
HM		HM0~HM959 ^{*1}	960
SM		Special SM0~SM2047 ^{*2}	2048
S	Process	S0~S1023	1024
HS		HS0~HS127 ^{*1}	128
T	Timer	T0~T575	576

HT		HT0~HT95 ^{*1}	96
ET		Precise timer ET0~ET31	16
C	Counter	C0~C575	576
HC		HC0~HC95 ^{*1}	96
HSC		High speed counter HSC0~HSC31	16
D		D0~D7999	8000
HD	Data register	HD0~HD999 ^{*1}	1000
SD		Special SD0~SD2047	2048
HSD		Special HSD0~HSD499 ^{*2}	500
FD		FlashROM register	FD0~FD6143
SFD	Special SFD0~SFD1999 ^{*2}		2000
FS	Special secrecy register	FS0~FS47	16
ID ^{*5}	Main unit	ID0~99	100
	Expansion BD	ID20000~20099 (#1 expansion BD)	300
QD ^{*6}	Main unit	QD0~99	100
	Expansion BD	QD20000~20099 (#1 expansion BD)	100
SEM	Sequence block instruction WAIT Special coil	SEM0~SEM31	32

Notes:

※1: the memory area is latched area, the area cannot be changed.

※2: Special using, is occupied by the system, cannot be used for other purposes.

※4: Extended BD I/O address allocation (octal number system)

※5: Analog input soft component address.

※6: Analog output soft component address.

3-3. HMI programming

ZG3 series HMI program is edited in TouchWin software. Please use the version 2.D and above.

Open the TouchWin software, click file/new, select TG765-MT/UT/ET/XT:

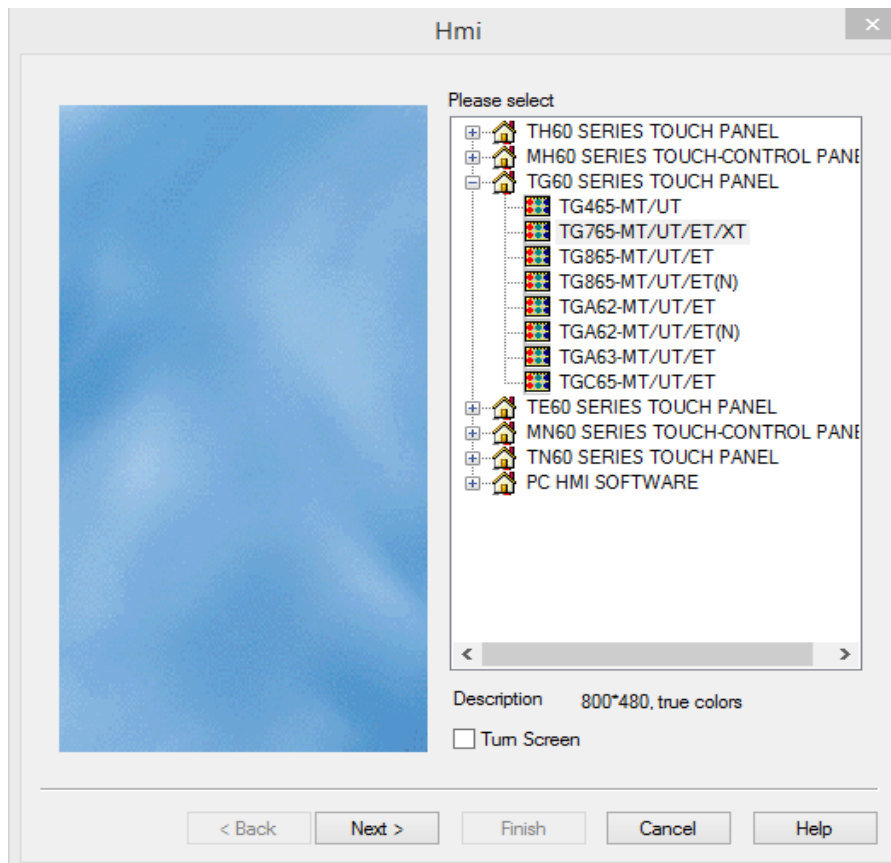

The programming method is similar to TG series HMI. The differences are ZG3 must choose XD/XE series PLC, otherwise, the HMI and PLC cannot communicate.

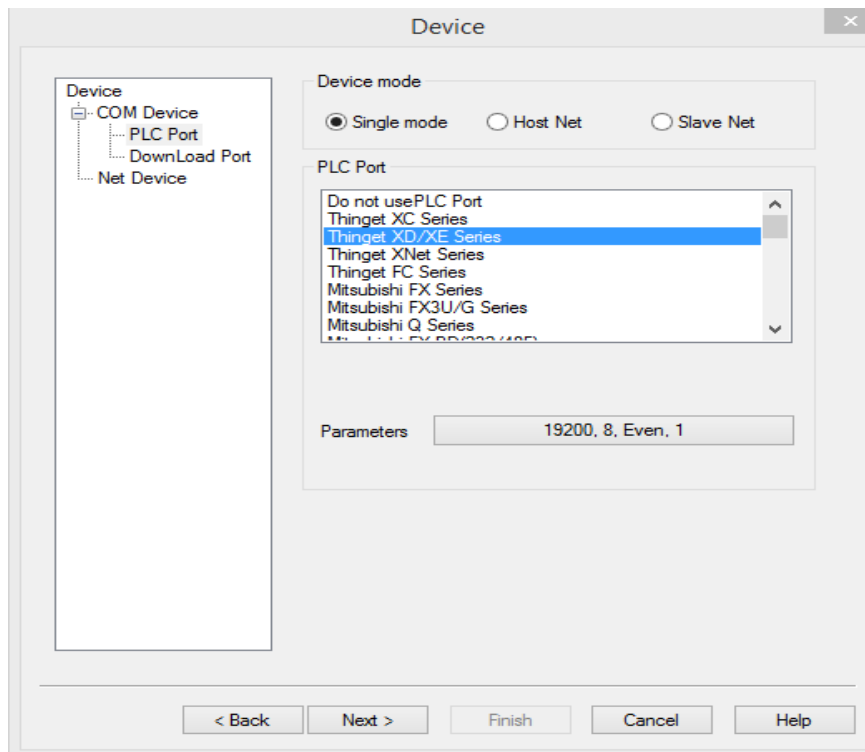

Download port device please select unuse download port.

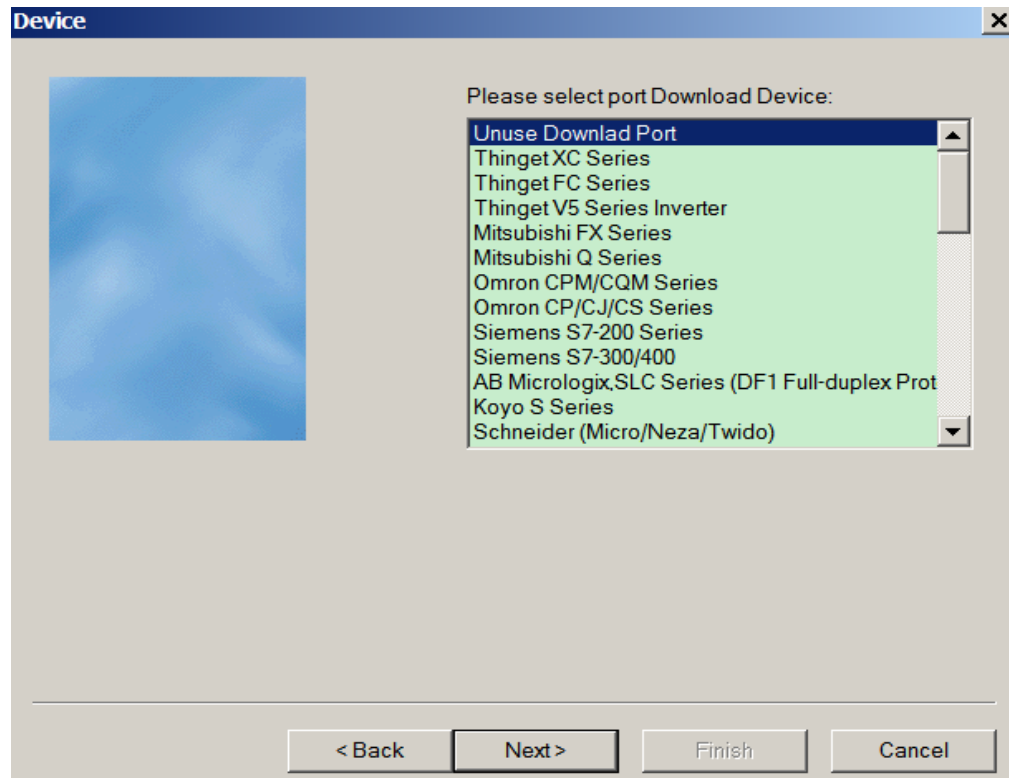

The programming method please refer to TG series HMI manual.

Appendix 1 special auxiliary register

Initial Status (SM0-SM3)

ID	Function	Description
SM000	Coil ON when running	
SM001	Coil OFF when running	
SM002	Initial positive pulse coil	
SM003	Initial negative pulse coil	

Clock (SM11-SM14)

ID	Function	Description
SM011	10ms frequency cycle	
SM012	100ms frequency cycle	
SM013	1s frequency cycle	
SM014	1min frequency cycle	

Mark (SM20-SM29)

ID	Function	Description
SM020	Zero bit	SM020 is ON when plus/minus operation result is 0
SM021	Borrow bit	SM021 is ON when minus operation overflows
SM022	Carry bit	SM022 is ON when plus operation overflows

PC Mode (SM32-SM34)

ID	Function	Description
SM032	Retentive register reset	When SM032 is ON, ON/OFF mapping memory of HM、HS and current values of HT、HC、HD will be reset.
SM033	Clear user's program	When SM033 is ON, all PLC user's program will be cleared.
SM034	All output forbidden	When SM034 is ON, all PLC external contacts will be set OFF.

Stepping Ladder

ID	Function	Description
SM040		

Interruption (SM50-SM80)

ID	Address	Function	Description
SM050	I000/I0001	Forbid input interruption 0	After executing EI instruction, the input interruption couldn't act independently when M acts, even if the interruption is allowed. E.g. : when SM050 is ON, I0000/I0001 is forbidden.
SM051	I0100/I0101	Forbid input interruption 1	
SM052	I0200/I0201	Forbid input interruption 2	
SM053	I0300/I0301	Forbid input interruption 3	
SM054	I0400/I0401	Forbid input interruption 4	
.....	
SM069	I1900/I1901	Forbid input interruption 19	After executing EI instruction, the timing interruption couldn't act independently when M acts, even if the interruption is allowed.
SM070	I40**	Forbid timing interruption 0	
SM071	I41**	Forbid timing interruption 1	
SM072	I42**	Forbid timing interruption 2	
SM073	I43**	Forbid timing interruption 3	
SM074	I44**	Forbid timing interruption 4	
.....	
SM089	I59**	Forbid timing interruption 19	
SM090		Forbid all interruptions	Forbid all interruptions

High Speed Pulse (SM140-SM199)

ID	Function	Description	
SM1000	'Sending pulse' flag	SM1000 will be ON when sending the pulse	PULSE_1
SM1001	Direction flag	SM1001 value being 1 stands for positive direction and corresponding port is ON	
SM1002	Overflow flag of accumulated pulse number	SM1002 value will be 1 when accumulated pulse number overflows.	
SM1003	Overflow flag of pulse equivalent	SM1003 value will be 1 when pulse equivalent overflows	
SM1004			
SM1005			
SM1006			
SM1007			
SM1008			
SM1009			
SM1010	Pulse error flag	SM1010 will be ON when pulse errors	PULSE_2
SM1020	'Sending pulse' flag	SM1020 will be ON when sending the pulse	
SM1021	Direction flag	SM1021 value being 1 stands for positive direction and corresponding port is ON	
SM1022	Overflow flag of accumulated pulse number	SM1022 value will be 1 when accumulated pulse number overflows.	
SM1023	Overflow flag of pulse equivalent	SM1023 value will be 1 when pulse equivalent overflows	
SM1024			
SM1025			
SM1026			
SM1027			
SM1028			
SM1029			PULSE_3
SM1030	Pulse error flag	SM1030 will be ON when pulse errors	
SM1040	'Sending pulse' flag	SM1040 will be ON when sending the pulse	
SM1041	Direction flag	SM1041 value being 1 stands for positive direction and corresponding port is ON	
SM1042	Overflow flag of accumulated pulse number	SM1042 value will be 1 when accumulated pulse number overflows.	PULSE_3
SM1043	Overflow flag of pulse	SM1043 value will be 1 when pulse equivalent	

	equivalent	overflows	
SM1044			
SM1045			
SM1046			
SM1047			
SM1048			
SM1049			
SM1050	Pulse error flag	SM1050 will be ON when pulse errors	
SM1060	'Sending pulse' flag	SM1060 will be ON when sending the pulse	PULSE_4
SM1061	Direction flag	SM1061 value being 1 stands for positive direction and corresponding port is ON	
SM1062	Overflow flag of accumulated pulse number	SM1062 value will be 1 when accumulated pulse number overflows.	
SM1063	Overflow flag of pulse equivalent	SM1063 value will be 1 when pulse equivalent overflows	
SM1064			
SM1065			
SM1066			
SM1067			
SM1068			
SM1069			
SM1070	Pulse error flag	SM1070 will be ON when pulse errors	
SM1080	'Sending pulse' flag	SM1080 will be ON when sending the pulse	PULSE_5
SM1081	Direction flag	SM1081 value being 1 stands for positive direction and corresponding port is ON	
SM1082	Overflow flag of accumulated pulse number	SM1082 value will be 1 when accumulated pulse number overflows.	
SM1083	Overflow flag of pulse equivalent	SM1083 value will be 1 when pulse equivalent overflows	
SM1084			
SM1085			
SM1086			
SM1087			
SM1088			
SM1089			
SM1090	Pulse error flag	SM1090 will be ON when pulse errors	
SM1100	'Sending pulse' flag	SM1100 will be ON when sending the pulse	PULSE_6
SM1101	Direction flag	SM1101 value being 1 stands for positive direction and corresponding port is ON	
SM1102	Overflow flag of accumulated pulse number	SM1102 value will be 1 when accumulated pulse number overflows.	

	number		
SM1103	Overflow flag of pulse equivalent	SM1103 value will be 1 when pulse equivalent overflows	
SM1104			
SM1105			
SM1106			
SM1107			
SM1108			
SM1109			
SM1110	Pulse error flag	SM1110 will be ON when pulse errors	
SM1120	'Sending pulse' flag	SM1120 will be ON when sending the pulse	PULSE_7
SM1121	Direction flag	SM1121 value being 1 stands for positive direction and corresponding port is ON	
SM1122	Overflow flag of accumulated pulse number	SM1122 value will be 1 when accumulated pulse number overflows.	
SM1123	Overflow flag of pulse equivalent	SM1123 value will be 1 when pulse equivalent overflows	
SM1124			
SM1125			
SM1126			
SM1127			
SM1128			
SM1129			
SM1130	Pulse error flag	SM1130 will be ON when pulse errors	
SM1140	'Sending pulse' flag	SM1140 will be ON when sending the pulse	PULSE_8
SM1141	Direction flag	SM1141 value being 1 stands for positive direction and corresponding port is ON	
SM1142	Overflow flag of accumulated pulse number	SM1142 value will be 1 when accumulated pulse number overflows.	
SM1143	Overflow flag of pulse equivalent	SM1143 value will be 1 when pulse equivalent overflows	
SM1144			
SM1145			
SM1146			
SM1147			
SM1148			
SM1149			
SM1150	Pulse error flag	SM1150 will be ON when pulse errors	
SM1160	'Sending pulse' flag	SM1160 will be ON when sending the pulse	PULSE_9
SM1161	Direction flag	SM1161 value being 1 stands for positive direction and corresponding port is ON	

SM1162	Overflow flag of accumulated pulse number	SM1162 value will be 1 when accumulated pulse number overflows.	
SM1163	Overflow flag of pulse equivalent	SM1163 value will be 1 when pulse equivalent overflows	
SM1164			
SM1165			
SM1166			
SM1167			
SM1168			
SM1169			
SM1170	Pulse error flag	SM1170 will be ON when pulse errors	
SM1180	'Sending pulse' flag	SM1180 will be ON when sending the pulse	
SM1181	Direction flag	SM1181 value being 1 stands for positive direction and corresponding port is ON	
SM1182	Overflow flag of accumulated pulse number	SM1182 value will be 1 when accumulated pulse number overflows.	
SM1183	Overflow flag of pulse equivalent	SM1183 value will be 1 when pulse equivalent overflows	
SM1184			
SM1185			
SM1186			
SM1187			
SM1188			
SM1189			
SM1190	Pulse error flag	SM1190 will be ON when pulse errors	

Sequence Function BLOCK (SM240-SM339)

ID	Function	Description
SM300	BLOCK1 running flag	SM300 will be ON when block1 is running
SM301	BLOCK2 running flag	SM301 will be ON when block2 is running
SM302	BLOCK3 running flag	SM302 will be ON when block3 is running
SM303	BLOCK4 running flag	SM303 will be ON when block4 is running
SM304	BLOCK5 running flag	SM304 will be ON when block5 is running
SM305	BLOCK6 running flag	SM305 will be ON when block6 is running
.....	
SM396	BLOCK97 running flag	SM396 will be ON when block97 is running
SM397	BLOCK98 running flag	SM397 will be ON when block98 is running
SM398	BLOCK99 running flag	SM398 will be ON when block99 is running
SM399	BLOCK100 running flag	SM399 will be ON when block100 is running

Error check (SM400-SM413)

ID	Function	Description
SM400	I/O error	ERR LED keeps ON, PLC don not run and output, check when power on
SM401	Expansion module communication error	
SM402	BD communication error	
.....		
SM405	No user program	Internal code check wrong
SM406	User program error	Implement code or configuration table check wrong
SM407	SSFD check error	ERR LED keeps ON, PLC don not run and output, check when power on
SM408	Memory error	Can not erase or write Flash
SM409	Calculation error	
SM410	Offset overflow	Offset exceeds soft element range
SM411	FOR-NEXT overflow	Reset when power on or users can also reset by hand.
SM412	Invalid data fill	When offset of register overflows, the return value will be SM372 value
SM413		

Error Message (SM450-SM452)

ID	Function	Description
SM450	System error check	
SM451		
SM452		

Expansion Modules, BD Status (SM500)

ID	Function	Description
SM500	Module status read is finished	

Communication (SM130-SM1319)

COM1	ID	Function	Description
	SM130	Accurate receipt flag	
	SM131	Error receipt flag	

	SM132		
	SM133		
	SM134		
	SM135		
	SM136		
	SM137		
	SM138		
	SM139		
COM2	SM140	Accurate receipt flag	
	SM141	Error receipt flag	
	SM142		
	SM143		
	SM144		
	SM145		
	SM146		
	SM147		
	SM148		
	SM149		

Appendix 2 Special data registers

Clock (SD010-SD019)

ID	Function	Description
SD010	Current scan cycle	100us, us is the unit
SD011	Min scan time	100us, us is the unit
SD012	Max scan time	100us, us is the unit
SD013	Second (clock)	0~59 (BCD code)
SD014	Minute (clock)	0~59 (BCD code)
SD015	Hour (clock)	0~23 (BCD code)
SD016	Day (clock)	0~31 (BCD code)
SD017	Month (clock)	0~12 (BCD code)
SD018	Year (clock)	2000~2099 (BCD code)
SD019	Week (clock)	0 (Sunday) ~6 (Saturday) (BCD code)

Flag (SD020-SD031)

ID	Function	Description
SD020	Information of type	
SD021	Information of type	
:		
SD030	Information of type	
SD031	Information of type	

Step ladder (SD040)

ID	Function	Description
SD40	Flag of the executing process S	

High Speed Counting (SD100-SD109)

ID	Function	Description
SD100	Current segment (No. n segment)	HSC00
SD101	Current segment (No. n segment)	HSC02
SD102	Current segment (No. n segment)	HSC04
SD103	Current segment (No. n segment)	HSC06
SD104	Current segment (No. n segment)	HSC08
SD105	Current segment (No. n segment)	HSC10
SD106	Current segment (No. n segment)	HSC12
SD107	Current segment (No. n segment)	HSC14
SD108	Current segment (No. n segment)	HSC16
SD109	Current segment (No. n segment)	HSC18

Sequence Function Block (SD300-SD399)

ID	Function	Description
SD300	Executing instruction of BLOCK1	The value will be used when BLOCK monitors
SD301	Executing instruction of BLOCK2	The value will be used when BLOCK monitors
SD302	Executing instruction of BLOCK3	The value will be used when BLOCK monitors
SD303	Executing instruction of BLOCK4	The value will be used when BLOCK monitors
SD304	Executing instruction of BLOCK5	The value will be used when BLOCK monitors
SD305	Executing instruction of BLOCK6	The value will be used when BLOCK monitors
.....
SD396	Executing instruction of BLOCK97	The value will be used when BLOCK monitors

SD397	Executing instruction of BLOCK98	The value will be used when BLOCK monitors
SD398	Executing instruction of BLOCK99	The value will be used when BLOCK monitors
SD399	Executing instruction of BLOCK100	The value will be used when BLOCK monitors

Error Check (SD400-SD413)

SD401	Number of communication error expansion module	
SD402	Number of communication error BD	
.....		
SD405		
SD406		
SD407		
SD408		
SD409	Operation error code number	1: Divided by zero error 2: Former operand's address less than the latter one's of MRST,MSET 3: ENCO,DECO encoding, decoding instruction data bit overruns. 4: BDC code error 7: Square root error
SD410	Numbers of shift register D when migration overruns	
SD411		
SD412		
SD413		

High Speed Pulse (SD1000-SD1099)

ID	Function	Description	
SD1000	Current segment (No. n segment)		PULSE_1
SD1001			
SD1002	Low 16 bits of accumulated pulse number (the unit is the pulse number)		
SD1003	High 16 bits of accumulated pulse number		

SD1004	The low 16 bits of accumulated pulse number		
SD1005	High 16 bits of accumulated pulse number		
SD1006	Low 16 bits of current output frequency		
SD1007	high 16 bits of current output frequency		
SD1008	Low 16 bits of current output frequency(The unit is pulse equivalent)		
SD1009	High 16 bits of current output frequency		
SD1010	Wrong Pulse message	1: Pulse data block error 2 : Equivalent mode : pulse amount/turn, amount/ turn of movement is 0 3:Code of system parameters block error 4:Pulse data block exceeds max limit 10:Zero return do not set near point signal 11: Speed of zero return is 0 12: Crawling speed of zero return is 0 13: Directions of zero return speed and zero auxiliary speed differ	
SD1011	Pulse data block error		
SD1020	Current segment(No. n segment)		
SD1021			
SD1022	Low 16 bits of accumulated pulse number (the unit is pulse number)		
SD1023	High 16 bits of accumulated pulse number		
SD1024	Low 16 bits of accumulated pulse number		
SD1025	High 16 bits of accumulated pulse number		PULSE_2
SD1026	Low 16 bits of current output frequency(the unit is pulse number)		
SD1027	High 16 bits of current output frequency(the unit is pulse number)		
SD1028	Low 16 bits of current output frequency(the unit is pulse equivalent)		
SD1029	High 16 bits of current output frequency(the unit is pulse equivalent)		

SD1030	Wrong Pulse message	1: Pulse data block error 2 : Equivalent mode : pulse amount/turn, amount/ turn of movement is 0 3:Code of system parameters block error 4: Pulse data block exceeds max limit 10: Zero return do not set near point signal 11: Speed of zero return is 0 12: Crawling speed of zero return is 0 13 Direction of zero return speed and zero auxiliary speed	
SD1031	Code of error pulse block		
SD1040	Current segment(No. n segment)		
SD1041			
SD1042	Low 16 bits of accumulated pulse number (the unit is pulse number)		
SD1043	High 16 bits of accumulated pulse number (the unit is pulse number)		
SD1044	Low 16 bits of accumulated pulse number(the unit is pulse equivalent)		
SD1045	High 16 bits of accumulated pulse number(the unit is pulse equivalent)		
SD1046	Low 16 bits of current output frequency(the unit is pulse number)		
SD1047	High 16 bits of current output frequency(the unit is pulse number)		PULSE_3
SD1048	Low 16 bits of current output frequency(the unit is pulse equivalent)		
SD1049	High 16 bits of current output frequency(the unit is pulse equivalent)		
SD1050	Wrong Pulse message	1: Pulse data block error 2 : Equivalent mode : pulse amount/turn 、 amount/ turn of movement is 0 3:Code of system parameters block error 4: Pulse data block exceeds max limit	

		10: Zero return do not set near point signal 11: Speed of zero return is 0 12: Crawling speed of zero return is 0 13 Direction of zero return speed and zero auxiliary speed	
SD1051	Code of error pulse block		
SD1060	Current segment(No. n segment)		PULSE_4
SD1061			
SD1062	Low 16 bits of accumulated pulse number (the unit is pulse number)		
SD1063	High 16 bits of accumulated pulse number (the unit is pulse number)		
SD1064	Low 16 bits of accumulated pulse number(the unit is pulse equivalent)		
SD1065	High 16 bits of accumulated pulse number(the unit is pulse equivalent)		
SD1066	Low 16 bits of current output frequency(the unit is pulse number)		
SD1067	High 16 bits of current output frequency(the unit is pulse number)		
SD1068	Low 16 bits of current output frequency(the unit is pulse equivalent)		
SD1069	High 16 bits of current output frequency(the unit is pulse equivalent)		
SD1070	Wrong Pulse message	1: Pulse data block error 2 : Equivalent mode : pulse amount/turn 、 amount/ turn of movement is 0 3:Code of system parameters block error 4: Pulse data block exceeds max limit 10: Zero return do not set near point signal 11: Speed of zero return is 0 12: Crawling speed of zero return is 0 13 Direction of zero return speed and zero auxiliary speed	
SD1071	Code of error pulse block		

SD1080	Current segment(No. n segment)		PULSE_5
SD1082	Low 16 bits of accumulated pulse number (the unit is pulse number)		
SD1083	High 16 bits of accumulated pulse number (the unit is pulse number)		
SD1084	Low 16 bits of accumulated pulse number(the unit is pulse equivalent)		
SD1085	High 16 bits of accumulated pulse number(the unit is pulse equivalent)		
SD1086	Low 16 bits of current output frequency(the unit is pulse number)		
SD1087	High 16 bits of current output frequency(the unit is pulse number)		
SD1088	Low 16 bits of current output frequency(the unit is pulse equivalent)		
SD1089	High 16 bits of current output frequency(the unit is pulse equivalent)		
SD1090	Wrong Pulse message	1: Pulse data block error 2 : Equivalent mode : pulse amount/turn 、 amount/ turn of movement is 0 3:Code of system parameters block error 4: Pulse data block exceeds max limit 10: Zero return do not set near point signal 11: Speed of zero return is 0 12: Crawling speed of zero return is 0 13 Direction of zero return speed and zero auxiliary speed	
SD1091	Code of error pulse block		
SD1100	Current segment(No. n segment)		PULSE_6
SD1102	Low 16 bits of accumulated pulse number (the unit is pulse number)		
SD1103	High 16 bits of accumulated pulse number (the unit is pulse number)		

SD1104	Low 16 bits of accumulated pulse number(the unit is pulse equivalent)		
SD1105	High 16 bits of accumulated pulse number(the unit is pulse equivalent)		
SD1106	Low 16 bits of current output frequency(the unit is pulse number)		
SD1107	High 16 bits of current output frequency(the unit is pulse number)		
SD1108	Low 16 bits of current output frequency(the unit is pulse equivalent)		
SD1109	High 16 bits of current output frequency(the unit is pulse equivalent)		
SD1110	Wrong Pulse message	1: Pulse data block error 2:Equivalent mode: pulse amount/turn, amount/ turn of movement is 0 3:Code of system parameters block error 4:Pulse data block exceeds max limit 10:Zero return do not set near point signal 11:Speed of zero return is 0 12:Crawling speed of zero return is 0 13 Direction of zero return speed and zero auxiliary speed	
SD1111	Code of error pulse block		
SD1120	Current segment(No. n segment)		
SD1122	Low 16 bits of accumulated pulse number (the unit is pulse number)		PULSE_7
SD1123	High 16 bits of accumulated pulse number (the unit is pulse number)		
SD1124	Low 16 bits of accumulated pulse number(the unit is pulse equivalent)		
SD1125	High 16 bits of accumulated pulse number(the unit is pulse equivalent)		
SD1126	Low 16 bits of current output frequency(the unit is pulse number)		
SD1127	High 16 bits of current output frequency(the unit is pulse number)		

SD1128	Low 16 bits of current output frequency(the unit is pulse equivalent)		
SD1129	High 16 bits of current output frequency(the unit is pulse equivalent)		
SD1130	Wrong Pulse message	1: Pulse data block error 2:Equivalent mode: pulse amount/turn, amount/ turn of movement is 0 3:Code of system parameters block error 4:Pulse data block exceeds max limit 10:Zero return do not set near point signal 11:Speed of zero return is 0 12:Crawling speed of zero return is 0 13 Direction of zero return speed and zero auxiliary speed	
SD1131	Code of error pulse block		
SD1140	Current segment(No. n segment)		
SD1142	Low 16 bits of accumulated pulse number (the unit is pulse number)		
SD1143	High 16 bits of accumulated pulse number (the unit is pulse number)		
SD1144	Low 16 bits of accumulated pulse number(the unit is pulse equivalent)		
SD1145	High 16 bits of accumulated pulse number(the unit is pulse equivalent)		
SD1146	Low 16 bits of current output frequency(the unit is pulse number)		PULSE_8
SD1147	High 16 bits of current output frequency(the unit is pulse number)		
SD1148	Low 16 bits of current output frequency(the unit is pulse equivalent)		
SD1149	High 16 bits of current output frequency(the unit is pulse equivalent)		
SD1150	Wrong Pulse message	1: Pulse data block error 2:Equivalent mode: pulse amount/turn, amount/ turn of movement is 0 3:Code of system parameters block	

		error 4:Pulse data block exceeds max limit 10:Zero return do not set near point signal 11:Speed of zero return is 0 12:Crawling speed of zero return is 0 13 Direction of zero return speed and zero auxiliary speed	
SD1151	Code of error pulse block		
SD1160	Current segment(No. n segment)		
SD1162	Low 16 bits of accumulated pulse number (the unit is pulse number)		
SD1163	High 16 bits of accumulated pulse number (the unit is pulse number)		
SD1164	Low 16 bits of accumulated pulse number(the unit is pulse equivalent)		
SD1165	High 16 bits of accumulated pulse number(the unit is pulse equivalent)		
SD1166	Low 16 bits of current output frequency(the unit is pulse number)		
SD1167	High 16 bits of current output frequency(the unit is pulse number)		
SD1168	Low 16 bits of current output frequency(the unit is pulse equivalent)		PULSE_9
SD1169	High 16 bits of current output frequency(the unit is pulse equivalent)		
SD1170	Wrong Pulse message	1: Pulse data block error 2:Equivalent mode: pulse amount/turn, amount/ turn of movement is 0 3:Code of system parameters block error 4:Pulse data block exceeds max limit 10:Zero return do not set near point signal 11:Speed of zero return is 0 12:Crawling speed of zero return is 0 13 Direction of zero return speed and zero auxiliary speed	

SD1171	Code of error pulse block		
SD1180	Current segment(No. n segment)		
SD1182	Low 16 bits of accumulated pulse number (the unit is pulse number)		
SD1183	High 16 bits of accumulated pulse number (the unit is pulse number)		
SD1184	Low 16 bits of accumulated pulse number(the unit is pulse equivalent)		
SD1185	High 16 bits of accumulated pulse number(the unit is pulse equivalent)		
SD1186	Low 16 bits of current output frequency(the unit is pulse number)		
SD1187	High 16 bits of current output frequency(the unit is pulse number)		
SD1188	Low 16 bits of current output frequency(the unit is pulse equivalent)		
SD1189	High 16 bits of current output frequency(the unit is pulse equivalent)		PULSE_1 0
SD1190	Wrong Pulse message	1: Pulse data block error 2:Equivalent mode: pulse amount/turn, amount/ turn of movement is 0 3:Code of system parameters block error 4:Pulse data block exceeds max limit 10:Zero return do not set near point signal 11:Speed of zero return is 0 12:Crawling speed of zero return is 0 13 Direction of zero return speed and zero auxiliary speed	
SD1191	Code of error pulse block		

Error Check (SD450-SD452)

ID	Function	Description
SD450	1: Watchdog act (Default 200ms) 2: Control block application fail 3: Visit illegal address	
SD451	Hardware error type: 1: Register error 2: Bus error 3: Usage error	
SD452	Hardware error	

Expansion Modules, BD Status (SD500-SD516)

ID	Function	Description	
SD500	Module number Expansion modules: #1~16 BD: #10001~10005		
SD501~516	Expansion module、BD status		16 registers

Modules Information (SD520-SD855)

ID	Function	Description	
SD520		Expansion module 1	Each expansion module occupies 16 registers
.....			
SD535			
.....	
SD760		Expansion module 16	
.....			
SD775			
SD776		BD module 1	Each BD module occupies 16 registers
.....			
SD791			
.....	
SD840		BD module 5	
.....			
SD855			

Expansion Module Error Information

ID	Function	Description	
SD860	Error times of module read		Expansion module 1
SD861	Error types of module read	Expansion's CRC parity error Expansion's address error Expansion accepted data length error Expansion's accept buffer zone overflows Expansion timeout error CRC parity error when PLC is accepting data Unknown error	
SD862	Error times of module write		
SD863	Error types of module write		
SD864	Error times of module read		Expansion module 2
SD865	Error types of module read	Expansion's CRC parity error Expansion's address error Expansion accepted data length error Expansion's accept buffer zone overflows Expansion timeout error CRC parity error when PLC is accepting data Unknown error	
SD866	Error times of module write		
SD867	Error types of module write		
.....			
SD920	Error times of module read		Expansion module 16
SD921	Error types of module read	Expansion's CRC parity error Expansion's address error Expansion accepted data length error Expansion's accept buffer zone overflows Expansion timeout error CRC parity error when PLC is accepting data Unknown error	
SD922	Error times of module write		
SD923	Error types of module write		
SD924	Error times of module read		BD module 1
SD925	Error types of module read		
SD926	Error times of module write		
SD927	Error types of module write		
.....			

SD940			BD module 5
SD941			
SD942			
SD943			

Communication

	ID	Function	Description
COM 1	SD130		
			0: Correct Serial port communication error code : 13: No initial character 14: No ending character 100: Hardware error 101: Timeout error 108: CRC parity error 110: Station number error Modbus communication error code: 211: Function number do not support 212: Address error (overrun) 213: Data length error 214: Data error 215: Slave station busy 216: Data storage error
	SD131	Serial port communication error code	(Erase FLASH)
	SD132		
	SD133		
	SD134		
	SD135		
	SD136		
	SD137		
	SD138		
SD139			
COM 2	SD140		
	SD141	Serial port communication error code	0: Correct Serial port communication error code : 13: No initial character 14: No ending character 100: Hardware error 101: Timeout error

		108: CRC parity error 110: Station number error Modbus communication error code: 211: Function number do not support 212: Address error (overrun) 213: Data length error 214: Data error 215: Slave station busy 216: Data storage error (Erase FLASH)
	SD142	
	SD143	
	SD144	
	SD145	
	SD146	
	SD147	
	SD148	
	SD149	

Special Data Register HSD (Power off retentive)

ID	Function	Description
HSD0	Low 16 bits of accumulated pulse number (the unit is pulse number)	
HSD1	High 16 bits of accumulated pulse number (the unit is pulse number)	
HSD2	Low 16 bits of accumulated pulse number(the unit is pulse equivalent)	PULSE_1
HSD3	High 16 bits of accumulated pulse number(the unit is pulse equivalent)	
HSD4	Low 16 bits of accumulated pulse number (the unit is pulse number)	
HSD5	High 16 bits of accumulated pulse number (the unit is pulse number)	
HSD6	Low 16 bits of accumulated pulse number(the unit is pulse equivalent)	PULSE_2
HSD7	High 16 bits of accumulated pulse number(the unit is pulse equivalent)	
HSD8	Low 16 bits of accumulated pulse number (the unit is pulse number)	
HSD9	High 16 bits of accumulated pulse number (the unit is pulse number)	
HSD10	Low 16 bits of accumulated pulse number(the unit is pulse equivalent)	PULSE_3
HSD11	High 16 bits of accumulated pulse number(the unit is pulse equivalent)	
HSD12	Low 16 bits of accumulated pulse number (the unit is pulse number)	
HSD13	High 16 bits of accumulated pulse number (the unit is pulse number)	
HSD14	Low 16 bits of accumulated pulse number(the unit is pulse equivalent)	PULSE_4
HSD15	High 16 bits of accumulated pulse number(the unit is pulse equivalent)	
HSD16	Low 16 bits of accumulated pulse number (the unit is pulse number)	PULSE_5
HSD17	High 16 bits of accumulated pulse number (the unit is pulse number)	
HSD18	Low 16 bits of accumulated pulse number(the unit is pulse equivalent)	

HSD19	High 16 bits of accumulated pulse number(the unit is pulse equivalent)	
HSD20	Low 16 bits of accumulated pulse number (the unit is pulse number)	
HSD21	High 16 bits of accumulated pulse number (the unit is pulse number)	
HSD22	Low 16 bits of accumulated pulse number(the unit is pulse equivalent)	
HSD23	High 16 bits of accumulated pulse number(the unit is pulse equivalent)	PULSE_6
HSD24	Low 16 bits of accumulated pulse number (the unit is pulse number)	
HSD25	High 16 bits of accumulated pulse number (the unit is pulse number)	
HSD26	Low 16 bits of accumulated pulse number(the unit is pulse equivalent)	
HSD27	High 16 bits of accumulated pulse number(the unit is pulse equivalent)	PULSE_7
HSD28	Low 16 bits of accumulated pulse number (the unit is pulse number)	
HSD29	High 16 bits of accumulated pulse number (the unit is pulse number)	
HSD30	Low 16 bits of accumulated pulse number(the unit is pulse equivalent)	
HSD31	High 16 bits of accumulated pulse number(the unit is pulse equivalent)	PULSE_8
HSD32	Low 16 bits of accumulated pulse number (the unit is pulse number)	
HSD33	High 16 bits of accumulated pulse number (the unit is pulse number)	
HSD34	Low 16 bits of accumulated pulse number(the unit is pulse equivalent)	
HSD35	High 16 bits of accumulated pulse number(the unit is pulse equivalent)	PULSE_9
HSD36	Low 16 bits of accumulated pulse number (the unit is pulse number)	
HSD37	High 16 bits of accumulated pulse number (the unit is pulse number)	
HSD38	Low 16 bits of accumulated pulse number(the unit is pulse equivalent)	
HSD39	High 16 bits of accumulated pulse number(the unit is pulse equivalent)	PULSE_10

Appendix 3 Special Flash register

* means it works only after repowering

I filtering

ID	Function	Description
SFD0*	Input filter time	
SFD2*	Watchdog run-up time, default value is 200ms	

I Mapping

ID	Function	Description	
SFD10*	I00 corresponds to X**	Input terminal 0 corresponds to X** number	0xFF means terminal bad , 0xFE means terminal idle
SFD11*	I01 corresponds to X**		
SFD12*	I02 corresponds to X**		

.....		
SFD73*	I77 corresponds to X**	Default value is 77 (Octonary)	

O Mapping

ID	Function	Description	
SFD74*	O00 corresponds to Y**	Output terminal 0 correspond to Y** number	0xFF means terminal bad, 0xFE means terminal idle
		Default value is 0	
.....		
SFD134*	O77 corresponds to Y**	Default value is 77 (Octonary)	

I Attribute

ID	Function	Description	
SFD138*	I00 attribute	Attribute of input terminal 0	0: positive logic others : negative logic
SFD139*	I01 attribute		
.....		
SFD201*	I77 attribute		

High Speed Counting

ID	Function	Description
SFD320	HSC0 frequency times	2 : 2 times frequency ; 4: 4 times frequency(effective at AB phase counting mode)
SFD321	HSC2 frequency times	Ditto
SFD322	HSC4 frequency times	Ditto
SFD323	HSC6 frequency times	Ditto
SFD324	HSC8 frequency times	Ditto
SFD325	HSC10 frequency times	Ditto
SFD326	HSC12 frequency times	Ditto
SFD327	HSC14 frequency times	Ditto
SFD328	HSC16 frequency times	Ditto
SFD329	HSC18 frequency times	Ditto
SFD330	Bit selection of HSC absolute and relative (24 segment)	bit0 corresponds to HSC0 , bit1corresponds to HSC2, and so on, bit9 corresponds to HSC18 0: relative 1: absolute
SFD331	Interrupt circulating of 24 segments high speed counting	bit0 corresponds to HSC0 , bit1corresponds to HSC2, and so on, bit9 corresponds to HSC18 0: single

		1: loop
SFD332	CAM function	bit0 corresponds to HSC0 , bit1corresponds to HSC2, and so on, bit9 corresponds to HSC18 0: do not support CAM function 1: support CAM function

Expansion Module Configuration

ID	Function	Description	
SFD350			Configuration of the first expansion module
:			
SFD359			
SFD360			Configuration of the second expansion module
:			
SFD369			
:	:	:	
SFD500			Configuration of the 16th expansion module
:			
SFD509			
SFD510			Configuration 1 of BD module
:			
SFD519			
:	:	:	
SFD550			Configuration 5 of BD module
:			
SFD559			

Communication

ID	Function	Description	Note
COM 1			
SFD600*	Communication mode		Refer to the value meaning of corresponding bit
SFD601*	Communication format	Baud rate, data bit, stop bit, parity	Refer to the value meaning of corresponding bit
SFD602*	Judgment time of frame timeout	In characters	High 8 bits invalid
SFD603*	Judgment time of reply timeout		High 8 bits invalid
SFD604	Waiting time before sending		Unit ms

COM 2			
SFD610*	Communication mode		Refer to the value meaning of corresponding bit
SFD611*	Communication format	Baud rate, data bit, stop bit, parity	Refer to the value meaning of corresponding bit
SFD612*	Judgment time of frame timeout		Unit: ms
SFD613*	Judgment time of reply timeout		Unit: ms, if value is set 0, it means no timeout waiting
SFD614	Waiting time before sending		Unit: ms

Timeout:

If 'judgment time of frame timeout' is set 0, then it will finish after accepting one character; 8bit unsigned number.

If 'judgment time of reply timeout is set' 0, it means no timeout waiting; 16bits unsigned number.

If 'waiting time before sending' is set 0, it means no time-lapse; 16 bit unsigned number.

Value meaning of SFD600, SFD610 corresponding bits

Corresponding bit	Value meaning
0~7: Modbus station number	Modbus station number
8~15: Communication mode	0: modbus RTU mode (default value) 1: modbus ASCII mode 2: free-format

Value meaning of SFD601, SFD611 corresponding bits

Corresponding bit	Value meaning			
0~3: Baud rate	0x0, BaudRate600	0x1, BaudRate1200	0x2, BaudRate2400	0x3, BaudRate4800
	0x4, BaudRate9600	0x5, BaudRate19200	0x6, BaudRate38400	0x7, BaudRate57600
	0x8, BaudRate115200	0x9, BaudRate192000	0xA, BaudRate256000	0xB, BaudRate288000
	0xC, BaudRate384000	0xD, BaudRate512000	0xE, BaudRate576000	0xF, BaudRate768000
4~7: Data bit	0x0, 8 bits	0x1, 7 bits		
8~11: Stop bit	0x0, 2 bits		0x2, 1bit	
12~15: Odd-even parity	0x0, none	0x1, odd parity	0x2, even parity	

Reserved Motion Control Usage

ID	Function	Description	
----	----------	-------------	--

SFD900	Pulse parameters setting	<p>Bit 0: logic of pulse output 0: positive logic; 1: negative logic, default value is 0</p> <p>Bit 1: logic of pulse direction 0: positive logic; 1: negative logic, default value is 0</p> <p>Bit 8: unit of pulse 0: pulse number; 1: pulse equivalent, default value is 0</p>	Common parameters	pulse _1
SFD901	Reserved			
SFD902	Pulse number/1turn of low 16 bits			
SFD903	Pulse number/1turn of high 16 bits			
SFD904	Amount of movement/1turn of low 16 bits			
SFD905	Amount of movement/1turn of high 16 bits			
SFD906	Pulse direction terminal	Set number of terminal Y, 0xFF means no terminal		
SFD907	Direction delay time	Default value is 20, unit: ms		
SFD908	Positive compensation of gear clearance			
SFD909	Negative compensation of gear clearance			
SFD910	Low 16 bits of Electrical origin position			
SFD911	High 16 bits of Electrical origin position			
SFD912	Mechanical back to origin parameter setting	Bit0: Switch state setting of near point, 0 : Normally ON ; 1Normally OFF		
SFD913	Terminal setting of near point signal	Bit0~bit7: Assign the number of terminal X, 0Xff for not terminal		
SFD914	Z phase terminal setting	Bit0~bit7: Assign the number of terminal X, 0Xff for not terminal		

SFD915	Limit terminal setting	Bit7~bit0: Assign limit 1 number of terminal X, 0Xff for not terminal Bit15~bit8 : Assign limit 2 number of terminal X, 0Xff for not terminal		
SFD916	Terminal setting of origin auxiliary signal	Bit0~bit7: Assign the number of terminal X, 0Xff for not terminal		
SFD917	Terminal setting of zero clear CLR signal output terminal	Bit0~bit7: Assign the number of terminal Y, 0Xff for not terminal		
SFD918	Low 16 bits of return speed VH			
SFD919	High 16 bits of return speed VH			
SFD920	Low 16 bits of return speed VL			
SFD921	High 16 bits of return speed VL			
SFD922	Low 16 bits of crawling speed			
SFD923	High 16 bits of crawling speed			
SFD924	Low 16 bits of mechanical origin			
SFD925	High 16 bits of mechanical origin			
SFD926	Z phase number			
SFD927	CLR signal delay time	Default value is 20, unit: ms		
SFD936	G instruction parameter group using choice	Choose the G instruction parameter group		
...				
SFD950	Low 16 bits of pulse default speed	Only when speed= 0, default speed is used to transmit pulse.	The first set of parameters	
SFD951	High 16 bits of pulse default speed			
SFD952	Accelerating time of pulse default speed			
SFD953	Decelerating time of pulse default speed			
SFD954	Acc and dec time of tween			
SFD955	Reserved			
SFD956	Low 16 bits of max speed limiting			
SFD957	High 16 bits of max speed limiting			
SFD958	Low 16 bits of starting speed			
SFD959	High 16 bits of starting speed			
SFD960	Low 16 bits of ending speed			
SFD961	High 16 bits of ending speed			

SFD962	Curve acceleration time (ms)			
...				
SFD970	Low 16 bits of pulse default speed	Only when speed=0, default speed is used to transmit pulse.	Second set of parameters	
SFD971	High 16 bits of pulse default speed			
SFD972	Accelerating time of pulse default speed			
SFD973	Decelerating time of pulse default speed			
SFD974	Acc and Dec time of tween			
SFD975	Reserved			
SFD976	Low 16 bits of max speed limiting			
SFD977	High 16 bits of max speed limiting			
SFD978	Low 16 bits of starting speed			
SFD979	High 16 bits of starting speed			
SFD980	Low 16 bits of ending speed			
SFD981	High 16 bits of ending speed			
SFD982	Curve acceleration time (ms)			
...				
SFD990	Low 16 bits of pulse default speed	Only when speed=0, default speed is used to transmit pulse.		
SFD991	High 16 bits of pulse default speed			
SFD992	Accelerating time of pulse default speed			
SFD993	Decelerating time of pulse default speed			
SFD994	Acc and Dec time of tween			
SFD995	Reserved			
SFD996	Low 16 bits of max speed limiting			
SFD997	High 16 bits of max speed limiting			
SFD998	Low 16 bits of starting speed			
SFD999	High 16 bits of starting speed			
SFD1000	Low 16 bits of ending speed			
SFD1001	High 16 bits of ending speed			
SFD1002	Curve acceleration time (ms)			
...				

SFD1010	Low 16 bits of pulse default speed	Only when speed=0, default speed is used to transmit pulse.	Forth set of parameters	
SFD1011	High 16 bits of pulse default speed			
SFD1012	Accelerating time of pulse default speed			
SFD1013	Decelerating time of pulse default speed			
SFD1014	Acc and Dec time of tween			
SFD1015	Reserved			
SFD1016	Low 16 bits of max speed limiting			
SFD1017	High 16 bits of max speed limiting			
SFD1018	Low 16 bits of starting speed			
SFD1019	High 16 bits of starting speed			
SFD1020	Low 16 bits of ending speed			
SFD1021	High 16 bits of ending speed			
SFD1022	Curve acceleration time (ms)			
...				
SFD1030	Pulse parameters setting	Bit 0: logic of pulse output 0: positive logic; 1: negative logic , default is 0 Bit 1: logic of pulse direction 0: positive logic; 1: negative logic , default is 0 Bit 8: pulse unit 0: pulse number; 1: pulse equivalent, default is 0	Public parameters	PULSE_2
SFD1031				
SFD1032	Low 16 bits of pulse number per circle			
SFD1033	High 16 bits of pulse number per circle			
SFD1034	Low 16 bits of pulse equivalent per circle			
SFD1035	High 16 bits of pulse equivalent per circle			
SFD1036	Pulse direction terminal	Assign the number of terminal Y, 0xFF for no terminal		
SFD1037	Direction delay time	Default 20, unit: ms		

SFD1038	Positive compensation of gear gap	Negative compensation will also use this data when gear gap negative compensation =0		
SFD1039	Negative compensation of gear gap			
SFD1040	Low 16 bits of Electrical origin position			
SFD1041	High 16 bits of Electrical origin position			
SFD1042	Mechanical back to origin parameter setting	Bit0: Switch state setting of near point, 0 : Normally ON ; 1Normally OFF		
SFD1043	Terminal setting of near point signal	Bit0~bit7: Assign the number of terminal X, 0Xff for not terminal		
SFD1044	Z phase terminal setting	Bit0~bit7: Assign the number of terminal X, 0Xff for not terminal		
SFD1045	Limit terminal setting	Bit7~bit0: Assign limit 1 number of terminal X, 0Xff for not terminal Bit15~bit8 : Assign limit 2 number of terminal X, 0Xff for not terminal		
SFD1046	Terminal setting of origin auxiliary signal	Bit0~bit7: Assign the number of terminal X, 0Xff for not terminal		
SFD1047	Terminal setting of zero clear CLR signal output terminal	Bit0~bit7: Assign the number of terminal Y, 0Xff for not terminal		
SFD1048	Low 16 bits of return speed VH			
SFD1049	High 16 bits of return speed VH			
SFD1050	Low 16 bits of return speed VL			
SFD1051	High 16 bits of return speed VL			
SFD1052	Low 16 bits of crawling speed			
SFD1053	High 16 bits of crawling speed			
SFD1054	Low 16 bits of mechanical origin			
SFD1055	High 16 bits of mechanical origin			
SFD1056	Z phase number			
SFD1057	CLR signal delay time	Default 20, unit: ms		
SFD936	G instruction parameter group using choice	Choose the G instruction parameter group		
...				
SFD1080	Low 16 bits of pulse default speed	Only when speed=0, default speed is used to transmit pulse.	First set of parameters	

SFD1081	High 16 bits of pulse default speed		
SFD1082	Accelerating time of pulse default speed		
SFD1083	Decelerating time of pulse default speed		
SFD1084	Acc and Dec time of tween		
SFD1085	Reserved		
SFD1086	Low 16 bits of max speed limiting		
SFD1087	High 16 bits of max speed limiting		
SFD1088	Low 16 bits of starting speed		
SFD1089	High 16 bits of starting speed		
SFD1090	Low 16 bits of ending speed		
SFD1091	High 16 bits of ending speed		
SFD1092	Curve acceleration time (ms)		
...			
SFD1100	Low 16 bits of pulse default speed	Only when speed=0, default speed is used to transmit pulse.	Second set of parameters
SFD1101	High 16 bits of pulse default speed		
SFD1102	Accelerating time of pulse default speed		
SFD1103	Decelerating time of pulse default speed		
SFD1104	Acc and Dec time of tween		
SFD1105	Reserved		
SFD1106	Low 16 bits of max speed limiting		
SFD1107	High 16 bits of max speed limiting		
SFD1108	Low 16 bits of starting speed		
SFD1109	High 16 bits of starting speed		
SFD1110	Low 16 bits of ending speed		
SFD1111	High 16 bits of ending speed		
SFD1112	Curve acceleration time (ms)		
...			
SFD1120	Low 16 bits of pulse default speed	Only when speed=0, default speed is used to transmit pulse.	Third set of parameters
SFD1121	High 16 bits of pulse default speed		

SFD1122	Accelerating time of pulse default speed			
SFD1123	Decelerating time of pulse default speed			
SFD1124	Acc and Dec time of tween			
SFD1125	Reserved			
SFD1126	Low 16 bits of max speed limiting			
SFD1127	High 16 bits of max speed limiting			
SFD1128	Low 16 bits of starting speed			
SFD1129	High 16 bits of starting speed			
SFD1130	Low 16 bits of ending speed			
SFD1131	High 16 bits of ending speed			
SFD1132	Curve acceleration time (ms)			
...				
SFD1140	Low 16 bits of pulse default speed	Only when speed=0, default speed is used to transmit pulse.		
SFD1141	High 16 bits of pulse default speed			
SFD1142	Accelerating time of pulse default speed			
SFD1143	Decelerating time of pulse default speed			
SFD1144	Acc and Dec time of tween			
SFD1145	Reserved			Forth set of parameters
SFD1146	Low 16 bits of max speed limiting			
SFD1147	High 16 bits of max speed limiting			
SFD1148	Low 16 bits of starting speed			
SFD1149	High 16 bits of starting speed			
SFD1150	Low 16 bits of ending speed			
SFD1151	High 16 bits of ending speed			
SFD1152	Curve acceleration time (ms)			
...				

SFD1160	Pulse parameters setting	Bit 0: logic of pulse output 0: positive logic; 1: negative logic , default is 0 Bit 1: logic of pulse direction 0: positive logic; 1: negative logic , default is 0 Bit 8: pulse unit 0: pulse number; 1: pulse equivalent, default is 0	Public parameters	PULSE_3
SFD1161				
SFD1162	Low 16 bits of pulse number per circle			
SFD1163	High 16 bits of pulse number per circle			
SFD1164	Low 16 bits of pulse equivalent per circle			
SFD1165	High 16 bits of pulse equivalent per circle			
SFD1166	Pulse direction terminal	Assign the number of terminal Y, 0xFF for no terminal		
SFD1167	Direction delay time	Default 20, unit: ms		
SFD1168	Positive compensation of gear gap	Negative compensation will also use this data when gear gap negative compensation =0		
SFD1169	Negative compensation of gear gap			
SFD1170	Low 16 bits of Electrical origin position			
SFD1171	High 16 bits of Electrical origin position			
SFD1172	Mechanical back to origin parameter setting	Bit0: Switch state setting of near point, 0 : Normally ON ; 1Normally OFF		
SFD1173	Terminal setting of near point signal	Bit0~bit7: Assign the number of terminal X, 0Xff for not terminal		
SFD1174	Z phase terminal setting	Bit0~bit7: Assign the number of terminal X, 0Xff for not terminal		
SFD1175	Limit terminal setting	Bit7~bit0: Assign limit 1 number of terminal X, 0Xff for not terminal Bit15~bit8 : Assign limit 2 number of terminal X, 0Xff for not terminal		

SFD1176	Terminal setting of origin auxiliary signal	Bit0~bit7: Assign the number of terminal X, 0Xff for not terminal		
SFD1177	Terminal setting of zero clear CLR signal output terminal	Bit0~bit7: Assign the number of terminal Y, 0Xff for not terminal		
SFD1178	Low 16 bits of return speed VH			
SFD1179	High 16 bits of return speed VH			
SFD1180	Low 16 bits of return speed VL			
SFD1181	High 16 bits of return speed VL			
SFD1182	Low 16 bits of crawling speed			
SFD1183	High 16 bits of crawling speed			
SFD1184	Low 16 bits of mechanical origin			
SFD1185	High 16 bits of mechanical origin			
SFD1186	Z phase number			
SFD1187	CLR signal delay time	Default 20, unit: ms		
SFD936	G instruction parameter group using choice	Choose the G instruction parameter group		
...				
SFD1210	Low 16 bits of pulse default speed	Only when speed=0, default speed is used to transmit pulse.	First set of parameters	
SFD1211	High 16 bits of pulse default speed			
SFD1212	Accelerating time of pulse default speed			
SFD1213	Decelerating time of pulse default speed			
SFD1214	Acc and Dec time of tween			
SFD1215	Reserved			
SFD1216	Low 16 bits of max speed limiting			
SFD1217	High 16 bits of max speed limiting			
SFD1218	Low 16 bits of starting speed			
SFD1219	High 16 bits of starting speed			
SFD1220	Low 16 bits of ending speed			
SFD1221	High 16 bits of ending speed			
SFD1222	Curve acceleration time (ms)			
...				
SFD1230	Low 16 bits of pulse default speed	Only when speed=0, default speed is used to transmit pulse.	Second set of parameters	
SFD1231	High 16 bits of pulse default speed			

SFD1232	Accelerating time of pulse default speed				
SFD1233	Decelerating time of pulse default speed				
SFD1234	Acc and Dec time of tween				
SFD1235	Reserved				
SFD1236	Low 16 bits of max speed limiting				
SFD1237	High 16 bits of max speed limiting				
SFD1238	Low 16 bits of starting speed				
SFD1239	High 16 bits of starting speed				
SFD1240	Low 16 bits of ending speed				
SFD1241	High 16 bits of ending speed				
SFD1242	Curve acceleration time (ms)				
...					
SFD1250	Low 16 bits of pulse default speed	Only when speed=0, default speed is used to transmit pulse.	Third set of parameters		
SFD1251	High 16 bits of pulse default speed				
SFD1252	Accelerating time of pulse default speed				
SFD1253	Decelerating time of pulse default speed				
SFD1254	Acc and Dec time of tween				
SFD1255	Reserved				
SFD1256	Low 16 bits of max speed limiting				
SFD1257	High 16 bits of max speed limiting				
SFD1258	Low 16 bits of starting speed				
SFD1259	High 16 bits of starting speed				
SFD1260	Low 16 bits of ending speed				
SFD1261	High 16 bits of ending speed				
SFD1262	Curve acceleration time (ms)				
...					
SFD1270	Low 16 bits of pulse default speed	Only when speed=0, default speed is used to transmit pulse.		Forth set of parameters	
SFD1271	High 16 bits of pulse default speed				
SFD1272	Accelerating time of pulse default speed				

SFD1273	Decelerating time of pulse default speed			
SFD1274	Acc and Dec time of tween			
SFD1275	Reserved			
SFD1276	Low 16 bits of max speed limiting			
SFD1277	High 16 bits of max speed limiting			
SFD1278	Low 16 bits of starting speed			
SFD1279	High 16 bits of starting speed			
SFD1280	Low 16 bits of ending speed			
SFD1281	High 16 bits of ending speed			
SFD1282	Curve acceleration time (ms)			
...				
SFD1290	Pulse parameters setting	Bit 0: logic of pulse output 0: positive logic; 1: negative logic , default is 0 Bit 1: logic of pulse direction 0: positive logic; 1: negative logic , default is 0 Bit 8: pulse unit 0: pulse number; 1: pulse equivalent, default is 0		
SFD1291				
SFD1292	Low 16 bits of pulse number per circle			
SFD1293	High 16 bits of pulse number per circle			
SFD1294	Low 16 bits of pulse equivalent per circle			
SFD1295	High 16 bits of pulse equivalent per circle			
SFD1296	Pulse direction terminal	Assign the number of terminal Y, 0xFF for no terminal		
SFD1297	Direction delay time	Default 20, unit: ms		
SFD1298	Positive compensation of gear gap	Negative compensation will also use this data when gear gap negative compensation =0		
SFD1299	Negative compensation of gear gap			
SFD1300	Low 16 bits of Electrical origin position			
			Public parameters	PULSE_4

SFD1301	High 16 bits of Electrical origin position			
SFD1302	Mechanical back to origin parameter setting	Bit0: Switch state setting of near point, 0 : Normally ON ; 1Normally OFF		
SFD1303	Terminal setting of near point signal	Bit0~bit7: Assign the number of terminal X, 0Xff for not terminal		
SFD1304	Z phase terminal setting	Bit0~bit7: Assign the number of terminal X, 0Xff for not terminal		
SFD1305	Limit terminal setting	Bit7~bit0: Assign limit 1 number of terminal X, 0Xff for not terminal Bit15~bit8 : Assign limit 2 number of terminal X, 0Xff for not terminal		
SFD1306	Terminal setting of origin auxiliary signal	Bit0~bit7: Assign the number of terminal X, 0Xff for not terminal		
SFD1307	Terminal setting of zero clear CLR signal output terminal	Bit0~bit7: Assign the number of terminal Y, 0Xff for not terminal		
SFD1308	Low 16 bits of return speed VH			
SFD1309	High 16 bits of return speed VH			
SFD1310	Low 16 bits of return speed VL			
SFD1311	High 16 bits of return speed VL			
SFD1312	Low 16 bits of crawling speed			
SFD1313	High 16 bits of crawling speed			
SFD1314	Low 16 bits of mechanical origin			
SFD1315	High 16 bits of mechanical origin			
SFD1316	Z phase number			
SFD1317	CLR signal delay time	Default 20, unit: ms		
SFD936	G instruction parameter group using choice	Choose the G instruction parameter group		
...				
SFD1340	Low 16 bits of pulse default speed	Only when speed=0, default speed is used to transmit pulse.	First set of parameters	
SFD1341	High 16 bits of pulse default speed			
SFD1342	Accelerating time of pulse default speed			
SFD1343	Decelerating time of pulse default speed			
SFD1344	Acc and Dec time of tween			
SFD1345	Reserved			

SFD1346	Low 16 bits of max speed limiting			
SFD1347	High 16 bits of max speed limiting			
SFD1348	Low 16 bits of starting speed			
SFD1349	High 16 bits of starting speed			
SFD1350	Low 16 bits of ending speed			
SFD1351	High 16 bits of ending speed			
SFD1352	Curve acceleration time (ms)			
...				
SFD1360	Low 16 bits of pulse default speed	Only when speed=0, default speed is used to transmit pulse.	Second set of parameters	
SFD1361	High 16 bits of pulse default speed			
SFD1362	Accelerating time of pulse default speed			
SFD1363	Decelerating time of pulse default speed			
SFD1364	Acc and Dec time of tween			
SFD1365	Reserved			
SFD1366	Low 16 bits of max speed limiting			
SFD1367	High 16 bits of max speed limiting			
SFD1368	Low 16 bits of starting speed			
SFD1369	High 16 bits of starting speed			
SFD1370	Low 16 bits of ending speed			
SFD1371	High 16 bits of ending speed			
SFD1372	Curve acceleration time (ms)			
...				
SFD1380	Low 16 bits of pulse default speed	Only when speed=0, default speed is used to transmit pulse.	Third set of parameters	
SFD1381	High 16 bits of pulse default speed			
SFD1382	Accelerating time of pulse default speed			
SFD1383	Decelerating time of pulse default speed			
SFD1384	Acc and Dec time of tween			
SFD1385	Reserved			
SFD1386	Low 16 bits of max speed limiting			

SFD1387	High 16 bits of max speed limiting			
SFD1388	Low 16 bits of starting speed			
SFD1389	High 16 bits of starting speed			
SFD1390	Low 16 bits of ending speed			
SFD1391	High 16 bits of ending speed			
SFD1392	Curve acceleration time (ms)			
...				
SFD1400	Low 16 bits of pulse default speed	Only when speed=0, default speed is used to transmit pulse.	Forth set of parameters	
SFD1401	High 16 bits of pulse default speed			
SFD1402	Accelerating time of pulse default speed			
SFD1403	Decelerating time of pulse default speed			
SFD1404	Acc and Dec time of tween			
SFD1405	Reserved			
SFD1406	Low 16 bits of max speed limiting			
SFD1407	High 16 bits of max speed limiting			
SFD1408	Low 16 bits of starting speed			
SFD1409	High 16 bits of starting speed			
SFD1410	Low 16 bits of ending speed			
SFD1411	High 16 bits of ending speed			
SFD1412	Curve acceleration time (ms)			
...				
SFD1420	Pulse parameters setting	Bit 0: logic of pulse output 0: positive logic; 1: negative logic , default is 0 Bit 1: logic of pulse direction 0: positive logic; 1: negative logic , default is 0 Bit 8: pulse unit 0: pulse number; 1: pulse equivalent, default is 0	Public parameters	PULSE_5
SFD1421				
SFD1422	Low 16 bits of pulse number per circle			
SFD1423	High 16 bits of pulse number per circle			

SFD1424	Low 16 bits of pulse equivalent per circle			
SFD1425	High 16 bits of pulse equivalent per circle			
SFD1426	Pulse direction terminal	Assign the number of terminal Y, 0xFF for no terminal		
SFD1427	Direction delay time	Default 20, unit: ms		
SFD1428	Positive compensation of gear gap	Negative compensation will also use this data when gear gap negative compensation =0		
SFD1429	Negative compensation of gear gap			
SFD1430	Low 16 bits of Electrical origin position			
SFD1431	High 16 bits of Electrical origin position			
SFD1432	Mechanical back to origin parameter setting	Bit0: Switch state setting of near point, 0 : Normally ON ; 1Normally OFF		
SFD1433	Terminal setting of near point signal	Bit0~bit7: Assign the number of terminal X, 0Xff for not terminal		
SFD1434	Z phase terminal setting	Bit0~bit7: Assign the number of terminal X, 0Xff for not terminal		
SFD1435	Limit terminal setting	Bit7~bit0: Assign limit 1 number of terminal X, 0Xff for not terminal Bit15~bit8 : Assign limit 2 number of terminal X, 0Xff for not terminal		
SFD1436	Terminal setting of origin auxiliary signal	Bit0~bit7: Assign the number of terminal X, 0Xff for not terminal		
SFD1437	Terminal setting of zero clear CLR signal output terminal	Bit0~bit7: Assign the number of terminal Y, 0Xff for not terminal		
SFD1438	Low 16 bits of return speed VH			
SFD1439	High 16 bits of return speed VH			
SFD1440	Low 16 bits of return speed VL			
SFD1441	High 16 bits of return speed VL			
SFD1442	Low 16 bits of crawling speed			
SFD1443	High 16 bits of crawling speed			
SFD1444	Low 16 bits of mechanical origin			
SFD1445	High 16 bits of mechanical origin			
SFD1446	Z phase number			

SFD1447	CLR signal delay time	Default 20, unit: ms		
SFD936	G instruction parameter group using choice	Choose the G instruction parameter group		
...				
SFD1470	Low 16 bits of pulse default speed	Only when speed=0, default speed is used to transmit pulse.	First set of parameters	
SFD1471	High 16 bits of pulse default speed			
SFD1472	Accelerating time of pulse default speed			
SFD1473	Decelerating time of pulse default speed			
SFD1474	Acc and Dec time of tween			
SFD1475	Reserved			
SFD1476	Low 16 bits of max speed limiting			
SFD1477	High 16 bits of max speed limiting			
SFD1478	Low 16 bits of starting speed			
SFD1479	High 16 bits of starting speed			
SFD1480	Low 16 bits of ending speed			
SFD1481	High 16 bits of ending speed			
SFD1482	Curve acceleration time (ms)			
...				
SFD1490	Low 16 bits of pulse default speed	Only when speed=0, default speed is used to transmit pulse.		
SFD1491	High 16 bits of pulse default speed			
SFD1492	Accelerating time of pulse default speed			
SFD1493	Decelerating time of pulse default speed			
SFD1494	Acc and Dec time of tween			
SFD1495	Reserved			
SFD1496	Low 16 bits of max speed limiting			
SFD1497	High 16 bits of max speed limiting			
SFD1498	Low 16 bits of starting speed			
SFD1499	High 16 bits of starting speed			
SFD1500	Low 16 bits of ending speed			
SFD1501	High 16 bits of ending speed			
SFD1502	Curve acceleration time (ms)			

...				
SFD1510	Low 16 bits of pulse default speed	Only when speed=0, default speed is used to transmit pulse.	Third set of parameters	
SFD1511	High 16 bits of pulse default speed			
SFD1512	Accelerating time of pulse default speed			
SFD1513	Decelerating time of pulse default speed			
SFD1514	Acc and Dec time of tween			
SFD1515	Reserved			
SFD1516	Low 16 bits of max speed limiting			
SFD1517	High 16 bits of max speed limiting			
SFD1518	Low 16 bits of starting speed			
SFD1519	High 16 bits of starting speed			
SFD1520	Low 16 bits of ending speed			
SFD1521	High 16 bits of ending speed			
SFD1522	Curve acceleration time (ms)			
...				
SFD1530	Low 16 bits of pulse default speed	Only when speed=0, default speed is used to transmit pulse.		
SFD1531	High 16 bits of pulse default speed			
SFD1532	Accelerating time of pulse default speed			
SFD1533	Decelerating time of pulse default speed			
SFD1534	Acc and Dec time of tween			
SFD1535	Reserved			
SFD1536	Low 16 bits of max speed limiting			
SFD1537	High 16 bits of max speed limiting			
SFD1538	Low 16 bits of starting speed			
SFD1539	High 16 bits of starting speed			
SFD1540	Low 16 bits of ending speed			
SFD1541	High 16 bits of ending speed			
SFD1542	Curve acceleration time (ms)			
...				

SFD1550	Pulse parameters setting	Bit 0: logic of pulse output 0: positive logic; 1: negative logic , default is 0 Bit 1: logic of pulse direction 0: positive logic; 1: negative logic , default is 0 Bit 8: pulse unit 0: pulse number; 1: pulse equivalent, default is 0	Public parameters	PULSE_6
SFD1551				
SFD1552	Low 16 bits of pulse number per circle			
SFD1553	High 16 bits of pulse number per circle			
SFD1554	Low 16 bits of pulse equivalent per circle			
SFD1555	High 16 bits of pulse equivalent per circle			
SFD1556	Pulse direction terminal	Assign the number of terminal Y, 0xFF for no terminal		
SFD1557	Direction delay time	Default 20, unit: ms		
SFD1558	Positive compensation of gear gap	Negative compensation will also use this data when gear gap negative compensation =0		
SFD1559	Negative compensation of gear gap			
SFD1560	Low 16 bits of Electrical origin position			
SFD1561	High 16 bits of Electrical origin position			
SFD1562	Mechanical back to origin parameter setting	Bit0: Switch state setting of near point, 0 : Normally ON ; 1Normally OFF		
SFD1563	Terminal setting of near point signal	Bit0~bit7: Assign the number of terminal X, 0Xff for not terminal		
SFD1564	Z phase terminal setting	Bit0~bit7: Assign the number of terminal X, 0Xff for not terminal		
SFD1565	Limit terminal setting	Bit7~bit0: Assign limit 1 number of terminal X, 0Xff for not terminal Bit15~bit8 : Assign limit 2 number of terminal X, 0Xff for not terminal		

SFD1566	Terminal setting of origin auxiliary signal	Bit0~bit7: Assign the number of terminal X, 0Xff for not terminal		
SFD1567	Terminal setting of zero clear CLR signal output terminal	Bit0~bit7: Assign the number of terminal Y, 0Xff for not terminal		
SFD1568	Low 16 bits of return speed VH			
SFD1569	High 16 bits of return speed VH			
SFD1570	Low 16 bits of return speed VL			
SFD1571	High 16 bits of return speed VL			
SFD1572	Low 16 bits of crawling speed			
SFD1573	High 16 bits of crawling speed			
SFD1574	Low 16 bits of mechanical origin			
SFD1575	High 16 bits of mechanical origin			
SFD1576	Z phase number			
SFD1577	CLR signal delay time	Default 20, unit: ms		
SFD936	G instruction parameter group using choice	Choose the G instruction parameter group		
...				
SFD1600	Low 16 bits of pulse default speed	Only when speed=0, default speed is used to transmit pulse.	First set of parameters	
SFD1601	High 16 bits of pulse default speed			
SFD1602	Accelerating time of pulse default speed			
SFD1603	Decelerating time of pulse default speed			
SFD1604	Acc and Dec time of tween			
SFD1605	Reserved			
SFD1606	Low 16 bits of max speed limiting			
SFD1607	High 16 bits of max speed limiting			
SFD1608	Low 16 bits of starting speed			
SFD1609	High 16 bits of starting speed			
SFD1610	Low 16 bits of ending speed			
SFD1611	High 16 bits of ending speed			
SFD1612	Curve acceleration time (ms)			
...				
SFD1620	Low 16 bits of pulse default speed	Only when speed=0, default speed is used to transmit pulse.		Second set of parameters
SFD1621	High 16 bits of pulse default speed			

SFD1622	Accelerating time of pulse default speed				
SFD1623	Decelerating time of pulse default speed				
SFD1624	Acc and Dec time of tween				
SFD1625	Reserved				
SFD1626	Low 16 bits of max speed limiting				
SFD1627	High 16 bits of max speed limiting				
SFD1628	Low 16 bits of starting speed				
SFD1629	High 16 bits of starting speed				
SFD1630	Low 16 bits of ending speed				
SFD1631	High 16 bits of ending speed				
SFD1632	Curve acceleration time (ms)				
...					
SFD1640	Low 16 bits of pulse default speed	Only when speed=0, default speed is used to transmit pulse.	Third set of parameters		
SFD1641	High 16 bits of pulse default speed				
SFD1642	Accelerating time of pulse default speed				
SFD1643	Decelerating time of pulse default speed				
SFD1644	Acc and Dec time of tween				
SFD1645	Reserved				
SFD1646	Low 16 bits of max speed limiting				
SFD1647	High 16 bits of max speed limiting				
SFD1648	Low 16 bits of starting speed				
SFD1649	High 16 bits of starting speed				
SFD1650	Low 16 bits of ending speed				
SFD1651	High 16 bits of ending speed				
SFD1652	Curve acceleration time (ms)				
...					
SFD1660	Low 16 bits of pulse default speed	Only when speed=0, default speed is used to transmit pulse.		Forth set of parameters	
SFD1661	High 16 bits of pulse default speed				
SFD1662	Accelerating time of pulse default speed				

SFD1663	Decelerating time of pulse default speed			
SFD1664	Acc and Dec time of tween			
SFD1665	Reserved			
SFD1666	Low 16 bits of max speed limiting			
SFD1667	High 16 bits of max speed limiting			
SFD1668	Low 16 bits of starting speed			
SFD1669	High 16 bits of starting speed			
SFD1670	Low 16 bits of ending speed			
SFD1671	High 16 bits of ending speed			
SFD1542	Curve acceleration time (ms)			
...				
SFD1680	Pulse parameters setting	Bit 0: logic of pulse output 0: positive logic; 1: negative logic , default is 0 Bit 1: logic of pulse direction 0: positive logic; 1: negative logic , default is 0 Bit 8: pulse unit 0: pulse number; 1: pulse equivalent, default is 0		
SFD1681				
SFD1682	Low 16 bits of pulse number per circle			
SFD1683	High 16 bits of pulse number per circle			
SFD1684	Low 16 bits of pulse equivalent per circle			
SFD1685	High 16 bits of pulse equivalent per circle			
SFD1686	Pulse direction terminal	Assign the number of terminal Y, 0xFF for no terminal		
SFD1687	Direction delay time	Default 20, unit: ms		
SFD1688	Positive compensation of gear gap	Negative compensation will also use this data when gear gap negative compensation =0		
SFD1689	Negative compensation of gear gap			
SFD1690	Low 16 bits of Electrical origin position			
			Public parameters	PULSE_7

SFD1691	High 16 bits of Electrical origin position			
SFD1692	Mechanical back to origin parameter setting	Bit0: Switch state setting of near point, 0 : Normally ON ; 1Normally OFF		
SFD1693	Terminal setting of near point signal	Bit0~bit7: Assign the number of terminal X, 0Xff for not terminal		
SFD1694	Z phase terminal setting	Bit0~bit7: Assign the number of terminal X, 0Xff for not terminal		
SFD1695	Limit terminal setting	Bit7~bit0: Assign limit 1 number of terminal X, 0Xff for not terminal Bit15~bit8 : Assign limit 2 number of terminal X, 0Xff for not terminal		
SFD1696	Terminal setting of origin auxiliary signal	Bit0~bit7: Assign the number of terminal X, 0Xff for not terminal		
SFD1697	Terminal setting of zero clear CLR signal output terminal	Bit0~bit7: Assign the number of terminal Y, 0Xff for not terminal		
SFD1698	Low 16 bits of return speed VH			
SFD1699	High 16 bits of return speed VH			
SFD1700	Low 16 bits of return speed VL			
SFD1701	High 16 bits of return speed VL			
SFD1702	Low 16 bits of crawling speed			
SFD1703	High 16 bits of crawling speed			
SFD1704	Low 16 bits of mechanical origin			
SFD1705	High 16 bits of mechanical origin			
SFD1706	Z phase number			
SFD1707	CLR signal delay time	Default 20, unit: ms		
SFD936	G instruction parameter group using choice	Choose the G instruction parameter group		
...				
SFD1730	Low 16 bits of pulse default speed	Only when speed is 0, default speed is used to transmit pulse.	First set of parameters	
SFD1731	High 16 bits of pulse default speed			
SFD1732	Accelerating time of pulse default speed			
SFD1733	Decelerating time of pulse default speed			
SFD1734	Acc and Dec time of tween			
SFD1735	Reserved			

SFD1736	Low 16 bits of max speed limiting			
SFD1737	High 16 bits of max speed limiting			
SFD1738	Low 16 bits of starting speed			
SFD1739	High 16 bits of starting speed			
SFD1740	Low 16 bits of ending speed			
SFD1741	High 16 bits of ending speed			
SFD1742	Curve acceleration time (ms)			
...				
SFD1750	Low 16 bits of pulse default speed	Only when speed is 0, default speed is used to transmit pulse.	Second set of parameters	
SFD1751	High 16 bits of pulse default speed			
SFD1752	Accelerating time of pulse default speed			
SFD1753	Decelerating time of pulse default speed			
SFD1754	Acc and Dec time of tween			
SFD1755	Reserved			
SFD1756	Low 16 bits of max speed limiting			
SFD1757	High 16 bits of max speed limiting			
SFD1758	Low 16 bits of starting speed			
SFD1759	High 16 bits of starting speed			
SFD1760	Low 16 bits of ending speed			
SFD1761	High 16 bits of ending speed			
SFD1762	Curve acceleration time (ms)			
...				
SFD1770	Low 16 bits of pulse default speed	Only when speed=0, default speed is used to transmit pulse.		Third set of parameters
SFD1771	High 16 bits of pulse default speed			
SFD1772	Accelerating time of pulse default speed			
SFD1773	Decelerating time of pulse default speed			
SFD1774	Acc and Dec time of tween			
SFD1775	Reserved			
SFD1776	Low 16 bits of max speed limiting			

SFD1777	High 16 bits of max speed limiting					
SFD1778	Low 16 bits of starting speed					
SFD1779	High 16 bits of starting speed					
SFD1780	Low 16 bits of ending speed					
SFD1781	High 16 bits of ending speed					
SFD1782	Curve acceleration time (ms)					
...						
SFD1790	Low 16 bits of pulse default speed	Only when speed=0, default speed is used to transmit pulse.	Forth set of parameters			
SFD1791	High 16 bits of pulse default speed					
SFD1792	Accelerating time of pulse default speed					
SFD1793	Decelerating time of pulse default speed					
SFD1794	Acc and Dec time of tween					
SFD1795	Reserved					
SFD1796	Low 16 bits of max speed limiting					
SFD1797	High 16 bits of max speed limiting					
SFD1798	Low 16 bits of starting speed					
SFD1799	High 16 bits of starting speed					
SFD1800	Low 16 bits of ending speed					
SFD1801	High 16 bits of ending speed					
SFD1802	Curve acceleration time (ms)					
...						
SFD1810	Pulse parameters setting	Bit 0: logic of pulse output 0: positive logic; 1: negative logic , default is 0 Bit 1: logic of pulse direction 0: positive logic; 1: negative logic , default is 0 Bit 8: pulse unit 0: pulse number; 1: pulse equivalent, default is 0			Public parameters	PULSE_8
SFD1811						
SFD1812	Low 16 bits of pulse number per circle					
SFD1813	High 16 bits of pulse number per circle					

SFD1814	Low 16 bits of pulse equivalent per circle			
SFD1815	High 16 bits of pulse equivalent per circle			
SFD1816	Pulse direction terminal	Assign the number of terminal Y, 0xFF for no terminal		
SFD1817	Direction delay time	Default 20, unit: ms		
SFD1818	Positive compensation of gear gap	Negative compensation will also use this data when gear gap negative compensation =0		
SFD1819	Negative compensation of gear gap			
SFD1820	Low 16 bits of Electrical origin position			
SFD1821	High 16 bits of Electrical origin position			
SFD1822	Mechanical back to origin parameter setting	Bit0: Switch state setting of near point, 0 : Normally ON; 1Normally OFF		
SFD1823	Terminal setting of near point signal	Bit0~bit7: Assign the number of terminal X, 0Xff for not terminal		
SFD1824	Z phase terminal setting	Bit0~bit7: Assign the number of terminal X, 0Xff for not terminal		
SFD1825	Limit terminal setting	Bit7~bit0: Assign limit 1 number of terminal X, 0Xff for not terminal Bit15~bit8 : Assign limit 2 number of terminal X, 0Xff for not terminal		
SFD1826	Terminal setting of origin auxiliary signal	Bit0~bit7: Assign the number of terminal X, 0Xff for not terminal		
SFD1827	Terminal setting of zero clear CLR signal output terminal	Bit0~bit7: Assign the number of terminal Y, 0Xff for not terminal		
SFD1828	Low 16 bits of return speed VH			
SFD1829	High 16 bits of return speed VH			
SFD1830	Low 16 bits of return speed VL			
SFD1831	High 16 bits of return speed VL			
SFD1832	Low 16 bits of crawling speed			
SFD1833	High 16 bits of crawling speed			
SFD1834	Low 16 bits of mechanical origin			
SFD1835	High 16 bits of mechanical origin			
SFD1836	Z phase number			

SFD1837	CLR signal delay time	Default 20, unit: ms			
SFD936	G instruction parameter group using choice	Choose the G instruction parameter group			
...					
SFD1860	Low 16 bits of pulse default speed	Only when speed=0, default speed is used to transmit pulse.	First set of parameters		
SFD1861	High 16 bits of pulse default speed				
SFD1862	Accelerating time of pulse default speed				
SFD1863	Decelerating time of pulse default speed				
SFD1864	Acc and Dec time of tween				
SFD1865	Reserved				
SFD1866	Low 16 bits of max speed limiting				
SFD1867	High 16 bits of max speed limiting				
SFD1868	Low 16 bits of starting speed				
SFD1869	High 16 bits of starting speed				
SFD1870	Low 16 bits of ending speed				
SFD1871	High 16 bits of ending speed				
SFD1872	Curve acceleration time (ms)				
...					
SFD1880	Low 16 bits of pulse default speed	Only when speed=0, default speed is used to transmit pulse.		Second set of parameters	
SFD1881	High 16 bits of pulse default speed				
SFD1882	Accelerating time of pulse default speed				
SFD1883	Decelerating time of pulse default speed				
SFD1884	Acc and Dec time of tween				
SFD1885	Reserved				
SFD1886	Low 16 bits of max speed limiting				
SFD1887	High 16 bits of max speed limiting				
SFD1888	Low 16 bits of starting speed				
SFD1889	High 16 bits of starting speed				
SFD1890	Low 16 bits of ending speed				
SFD1891	High 16 bits of ending speed				
SFD1892	Curve acceleration time (ms)				

...				
SFD1900	Low 16 bits of pulse default speed	Only when speed=0, default speed is used to transmit pulse.	Third set of parameters	
SFD1901	High 16 bits of pulse default speed			
SFD1902	Accelerating time of pulse default speed			
SFD1903	Decelerating time of pulse default speed			
SFD1904	Acc and Dec time of tween			
SFD1905	Reserved			
SFD1906	Low 16 bits of max speed limiting			
SFD1907	High 16 bits of max speed limiting			
SFD1908	Low 16 bits of starting speed			
SFD1909	High 16 bits of starting speed			
SFD1910	Low 16 bits of ending speed			
SFD1911	High 16 bits of ending speed			
SFD1912	Curve acceleration time (ms)			
...				
SFD1920	Low 16 bits of pulse default speed	Only when speed=0, default speed is used to transmit pulse.		
SFD1921	High 16 bits of pulse default speed			
SFD1922	Accelerating time of pulse default speed			
SFD1923	Decelerating time of pulse default speed			
SFD1924	Acc and Dec time of tween			
SFD1925	Reserved			
SFD1926	Low 16 bits of max speed limiting			
SFD1927	High 16 bits of max speed limiting			
SFD1928	Low 16 bits of starting speed			
SFD1929	High 16 bits of starting speed			
SFD1930	Low 16 bits of ending speed			
SFD1931	High 16 bits of ending speed			
SFD1932	Curve acceleration time (ms)			
...				

SFD1940	Pulse parameters setting	Bit 0: logic of pulse output 0: positive logic; 1: negative logic , default is 0 Bit 1: logic of pulse direction 0: positive logic; 1: negative logic , default is 0 Bit 8: pulse unit 0: pulse number; 1: pulse equivalent, default is 0	Public parameters	PULSE_9
SFD1941				
SFD1942	Low 16 bits of pulse number per circle			
SFD1943	High 16 bits of pulse number per circle			
SFD1944	Low 16 bits of pulse equivalent per circle			
SFD1945	High 16 bits of pulse equivalent per circle			
SFD1946	Pulse direction terminal	Assign the number of terminal Y, 0xFF for no terminal		
SFD1947	Direction delay time	Default 20, unit: ms		
SFD1948	Positive compensation of gear gap	Negative compensation will also use this data when gear gap negative compensation =0		
SFD1949	Negative compensation of gear gap			
SFD1950	Low 16 bits of Electrical origin position			
SFD1951	High 16 bits of Electrical origin position			
SFD1952	Mechanical back to origin parameter setting	Bit0: Switch state setting of near point, 0 : Normally ON ; 1Normally OFF		
SFD1953	Terminal setting of near point signal	Bit0~bit7: Assign the number of terminal X, 0Xff for not terminal		
SFD1954	Z phase terminal setting	Bit0~bit7: Assign the number of terminal X, 0Xff for not terminal		
SFD1955	Limit terminal setting	Bit7~bit0: Assign limit 1 number of terminal X, 0Xff for not terminal Bit15~bit8 : Assign limit 2 number of terminal X, 0Xff for not terminal		

SFD1956	Terminal setting of origin auxiliary signal	Bit0~bit7: Assign the number of terminal X, 0Xff for not terminal		
SFD1957	Terminal setting of zero clear CLR signal output terminal	Bit0~bit7: Assign the number of terminal Y, 0Xff for not terminal		
SFD1958	Low 16 bits of return speed VH			
SFD1959	High 16 bits of return speed VH			
SFD1960	Low 16 bits of return speed VL			
SFD1961	High 16 bits of return speed VL			
SFD1962	Low 16 bits of crawling speed			
SFD1963	High 16 bits of crawling speed			
SFD1964	Low 16 bits of mechanical origin			
SFD1965	High 16 bits of mechanical origin			
SFD1966	Z phase number			
SFD1967	CLR signal delay time	Default 20, unit: ms		
SFD936	G instruction parameter group using choice	Choose the G instruction parameter group		
...				
SFD1990	Low 16 bits of pulse default speed	Only when speed=0, default speed is used to transmit pulse.	First set of parameters	
SFD1991	High 16 bits of pulse default speed			
SFD1992	Accelerating time of pulse default speed			
SFD1993	Decelerating time of pulse default speed			
SFD1994	Acc and Dec time of tween			
SFD1995	Reserved			
SFD1996	Low 16 bits of max speed limiting			
SFD1997	High 16 bits of max speed limiting			
SFD1998	Low 16 bits of starting speed			
SFD1999	High 16 bits of starting speed			
SFD2000	Low 16 bits of ending speed			
SFD2001	High 16 bits of ending speed			
SFD2002	Curve acceleration time (ms)			
...				
SFD2010	Low 16 bits of pulse default speed	Only when speed=0, default speed is used to transmit pulse.		Second set of parameters
SFD2011	High 16 bits of pulse default speed			

SFD2012	Accelerating time of pulse default speed				
SFD2013	Decelerating time of pulse default speed				
SFD2014	Acc and Dec time of tween				
SFD2015	Reserved				
SFD2016	Low 16 bits of max speed limiting				
SFD2017	High 16 bits of max speed limiting				
SFD2018	Low 16 bits of starting speed				
SFD2019	High 16 bits of starting speed				
SFD2020	Low 16 bits of ending speed				
SFD2021	High 16 bits of ending speed				
SFD2022	Curve acceleration time (ms)				
...					
SFD2030	Low 16 bits of pulse default speed	Only when speed=0, default speed is used to transmit pulse.	Third set of parameters		
SFD2031	High 16 bits of pulse default speed				
SFD2032	Accelerating time of pulse default speed				
SFD2033	Decelerating time of pulse default speed				
SFD2034	Acc and Dec time of tween				
SFD2035	Reserved				
SFD2036	Low 16 bits of max speed limiting				
SFD2037	High 16 bits of max speed limiting				
SFD2038	Low 16 bits of starting speed				
SFD2039	High 16 bits of starting speed				
SFD2040	Low 16 bits of ending speed				
SFD2041	High 16 bits of ending speed				
SFD2042	Curve acceleration time (ms)				
...					
SFD2050	Low 16 bits of pulse default speed	Only when speed=0, default speed is used to transmit pulse.		Forth set of parameters	
SFD2051	High 16 bits of pulse default speed				
SFD2052	Accelerating time of pulse default speed				

SFD2053	Decelerating time of pulse default speed			
SFD2054	Acc and Dec time of tween			
SFD2055	Reserved			
SFD2056	Low 16 bits of max speed limiting			
SFD2057	High 16 bits of max speed limiting			
SFD2058	Low 16 bits of starting speed			
SFD2059	High 16 bits of starting speed			
SFD2060	Low 16 bits of ending speed			
SFD2061	High 16 bits of ending speed			
SFD2062	Curve acceleration time (ms)			
...				
SFD2070	Pulse parameters setting	Bit 0: logic of pulse output 0: positive logic; 1: negative logic , default is 0 Bit 1: logic of pulse direction 0: positive logic; 1: negative logic , default is 0 Bit 8: pulse unit 0: pulse number; 1: pulse equivalent, default is 0		
SFD2071				
SFD2072	Low 16 bits of pulse number per circle			
SFD2073	High 16 bits of pulse number per circle			
SFD2074	Low 16 bits of pulse equivalent per circle			
SFD2075	High 16 bits of pulse equivalent per circle			
SFD2076	Pulse direction terminal	Assign the number of terminal Y, 0xFF for no terminal		
SFD2077	Direction delay time	Default 20, unit: ms		
SFD2078	Positive compensation of gear gap	Negative compensation will also use this data when gear gap negative compensation =0		
SFD2079	Negative compensation of gear gap			
SFD2080	Low 16 bits of Electrical origin position			
			Public parameters	PULSE_10

SFD2081	High 16 bits of Electrical origin position			
SFD2082	Mechanical back to origin parameter setting	Bit0: Switch state setting of near point, 0 : Normally ON ; 1Normally OFF		
SFD2083	Terminal setting of near point signal	Bit0~bit7: Assign the number of terminal X, 0Xff for not terminal		
SFD2084	Z phase terminal setting	Bit0~bit7: Assign the number of terminal X, 0Xff for not terminal		
SFD2085	Limit terminal setting	Bit7~bit0: Assign limit 1 number of terminal X, 0Xff for not terminal Bit15~bit8 : Assign limit 2 number of terminal X, 0Xff for not terminal		
SFD2086	Terminal setting of origin auxiliary signal	Bit0~bit7: Assign the number of terminal X, 0Xff for not terminal		
SFD2087	Terminal setting of zero clear CLR signal output terminal	Bit0~bit7: Assign the number of terminal Y, 0Xff for not terminal		
SFD2088	Low 16 bits of return speed VH			
SFD2089	High 16 bits of return speed VH			
SFD2090	Low 16 bits of return speed VL			
SFD2091	High 16 bits of return speed VL			
SFD2092	Low 16 bits of crawling speed			
SFD2093	High 16 bits of crawling speed			
SFD2094	Low 16 bits of mechanical origin			
SFD2095	High 16 bits of mechanical origin			
SFD2096	Z phase number			
SFD2097	CLR signal delay time	Default 20, unit: ms		
SFD936	G instruction parameter group using choice	Choose the G instruction parameter group		
...				
SFD2120	Low 16 bits of pulse default speed	Only when speed is 0, default speed is used to transmit pulse.	First set of parameters	
SFD2121	High 16 bits of pulse default speed			
SFD2122	Accelerating time of pulse default speed			
SFD2123	Decelerating time of pulse default speed			
SFD2124	Acc and Dec time of tween			
SFD2125	Reserved			

SFD2126	Low 16 bits of max speed limiting			
SFD2127	High 16 bits of max speed limiting			
SFD2128	Low 16 bits of starting speed			
SFD2129	High 16 bits of starting speed			
SFD2130	Low 16 bits of ending speed			
SFD2131	High 16 bits of ending speed			
SFD2132	Curve acceleration time (ms)			
...				
SFD2140	Low 16 bits of pulse default speed	Only when speed=0, default speed is used to transmit pulse.	Second set of parameters	
SFD2141	High 16 bits of pulse default speed			
SFD2142	Accelerating time of pulse default speed			
SFD2143	Decelerating time of pulse default speed			
SFD2144	Acc and Dec time of tween			
SFD2145	Reserved			
SFD2146	Low 16 bits of max speed limiting			
SFD2147	High 16 bits of max speed limiting			
SFD2148	Low 16 bits of starting speed			
SFD2149	High 16 bits of starting speed			
SFD2150	Low 16 bits of ending speed			
SFD2151	High 16 bits of ending speed			
SFD2152	Curve acceleration time (ms)			
...				
SFD2160	Low 16 bits of pulse default speed	Only when speed=0, default speed is used to transmit pulse.		Third set of parameters
SFD2161	High 16 bits of pulse default speed			
SFD2162	Accelerating time of pulse default speed			
SFD2163	Decelerating time of pulse default speed			
SFD2164	Acc and Dec time of tween			
SFD2165	Reserved			
SFD2166	Low 16 bits of max speed limiting			

SFD2167	High 16 bits of max speed limiting			
SFD2168	Low 16 bits of starting speed			
SFD2169	High 16 bits of starting speed			
SFD2170	Low 16 bits of ending speed			
SFD2171	High 16 bits of ending speed			
SFD2172	Curve acceleration time (ms)			
...				
SFD2180	Low 16 bits of pulse default speed	Only when speed=0, default speed is used to transmit pulse.	Forth set of parameters	
SFD2181	High 16 bits of pulse default speed			
SFD2182	Accelerating time of pulse default speed			
SFD2183	Decelerating time of pulse default speed			
SFD2184	Acc and Dec time of tween			
SFD2185	Reserved			
SFD2186	Low 16 bits of max speed limiting			
SFD2187	High 16 bits of max speed limiting			
SFD2188	Low 16 bits of starting speed			
SFD2189	High 16 bits of starting speed			
SFD2190	Low 16 bits of ending speed			
SFD2191	High 16 bits of ending speed			
SFD2192	Curve acceleration time (ms)			
...				

XINJE WUXI XINJE ELECTRIC CO., LTD.



4th Floor Building 7,Originality Industry
park, Liyuan Development Zone, Wuxi
City, Jiangsu Province

214072

Tel: (510) 85134136

Fax: (510) 85111290

www.xinje.com